

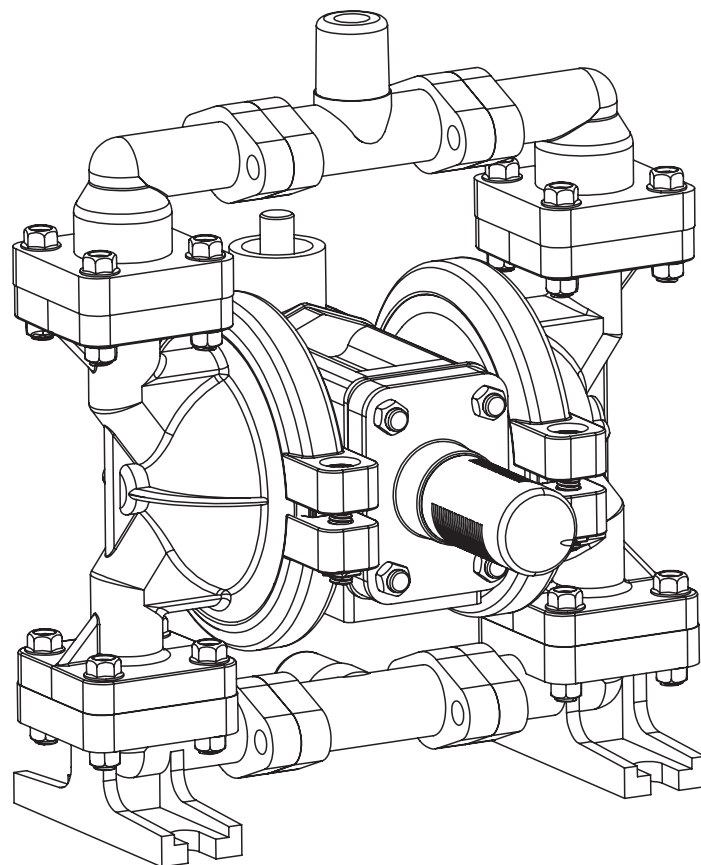

SERVICE & OPERATING MANUAL  
**AIR OPERATED DOUBLE DIAPHRAGM PUMP**



**HP02**

**FUGELPUMP**

## Index

### 1 - Attention Symbols and Warnings

- 1.1 - Attention Symbol
- 1.2 - Warnings
  - 1.2.1 - Equipment Misuse Hazard
  - 1.2.2 - Toxic Fluid Hazard
  - 1.2.3 - Fire and Explosion Hazard

### 2 - Installation

- 2.1 - General Information
  - 2.1.1 - Secure Operation Temperature for body
  - 2.1.2 - Secure Operation Temperature for Elastomer Parts
- 2.2 - Air Line
- 2.3 - Suction Line
- 2.4 - Compression Line
- 2.5 - Relieve Valve for Fluid Pressure
- 2.6 - Outlet Air Relief
- 2.7 - Grounding
- 2.8 - Washing and Cleaning the Pump
- 2.9 - Commissioning of the Pump
- 2.10 - Pressure Equipment Relief

### 3 - Operation

- 3.1 - Technical Information
  - 3.1.1 - Performance Curve and Pump Figure
  - 3.1.2 - Pump Type Coding
  - 3.1.3 - Spare Part Type Coding
  - 3.1.4 - Technical Specifications of the Pump
  - 3.1.5 - Pump Scaling with Plastic Body
  - 3.1.6 - Packaging Sizes and Weights
  - 3.1.7 - Spare Part Drawing (PLASTIC)

### 4 - Maintenance

- 4.1 - Diaphragm Maintenance
  - 4.1.1 - Removal of the Diaphragm
  - 4.1.2 - Installation of the Diaphragm
  - 4.1.3 - Installation of the Diaphragms to the Pump
- 4.2 - Air Valve Kit Types and Maintenance
- 4.3 - Pilot Valve Repair Kit Types and Maintenance
- 4.4 - Plastic Body Pump Check Valve Maintenance
- 4.5 - Torque Line in Plastic Body Pumps
- 4.6 - Problems That May Occur in the Pump and their Solutions

### 5 - Warranty Conditions

## 1-Attention Symbols and Warnings

### 1.1-Attention Symbol

Warning system is the following ATTENTION letter and symbol next to it. In case subjects referred by this symbol are not complied, serious accidents and injuries may occur. Even there may be loss of life as a result of serious accidents. Absolutely read and apply letters (warned) marked with this symbol. When you take these warnings seriously, this may save your life and minimize injury risk.



### CAUTION

#### 1.2 –Warnings

User's Manual booklet gives useful information from use and to installation, from repair to maintenance of pump. The User's Manual booklet includes information that aims at introducing you features, way of operation and security information of the pump. This manual also includes designed maintenance information to develop secure use of the pump. It is proposed that Gunalsan Pompa service makes the entire service and maintenance of the pump. Gunalsan Pompa service shall also provide other assistances and maintenance that may be needed in addition to its superior service and maintenance. The User's Manual should be considered as an integral part of the pump and you should keep it around you to apply whenever you want. In case these warning are not considered, there may be material damages in the pump or pump equipment.



### CAUTION

*The User's Manual booklet includes user and instructions and you should absolutely read it before using diaphragm pump. Manufacturer Company does not accept any responsibility regarding damage of the pump due to improper use.*

#### 1.2.1- Equipment Misuse Hazard

- Fluid to be transferred by the diaphragm pump is notified to authorized dealer or main dealer. The dealer determines pump that is compatible for fluid. Consult to Gunalsan Pompa or authorized dealer before pumping any other fluid than notified fluid transfer.

- Working pressure of the diaphragm pump is (max.) 7 bars. These pressure values should not be exceeded. Otherwise, diaphragm pump may be damaged or is not included within the scope of warranty.

- Use noise preventive ear plugs, protection goggles and gloves while installing the diaphragm pump for the first time or is put into use and as long as it continues to operate.

-While diaphragm pump is in operation and under pressure, do not lift the pump.

- Comply with necessary fire instructions and electricity and security instructions. (Local, National and Regional)

- Do not make any alteration on parts of the diaphragm pump. Use always (OEM) original spare parts.

- If you used flexible hose while installing the diaphragm pump, pay attention not to bend this hose during transfer.

- Hose in suction part should not be flexible during or after installing the diaphragm pump. Flexible hoses may be bended during suction and stop suction.

- Fluid to be transferred by the pump and pump body and elastomer (parts manufactured from rubber) materials should be compatible. If you do not sufficient information whether they are compatible or not, consult to Gunalsan Pompa or authorized dealer.

- If the Company producing fluid for fluid to be transferred with the diaphragm pump has any warning, please consider these warnings.

- Control diaphragm pump body, its diaphragms and other equipment each day. If any wear and tear is observed, immediately replace the part. When the diaphragm pump stops to operate and removed from line, if there is risk that fluid in it freezes, clean inside with a fluid compatible with this fluid. Otherwise, material freezing in the diaphragm pump may damage the body and diaphragms.

- Do not transfer trichloroethane, methylene chloride, other halogen hydrocarbon solvents or fluids containing such solvents in aluminum equipment that operate under pressure with these pumps. Use of these fluids may cause chemical reaction and their explosion possibility is high.

- Compliance of fluid to be transferred with pump body and elastomer parts should be determined while selecting diaphragm pump. Under improper situations, pump may be damaged, even there may be injury and death risk. If fluid to be transferred and pump body is improper, the Manufacturer Company is not responsible for all the damages that may occur in case **Gunalsan POMPA** did not make this selection.

- Make diaphragm pump connections at original inlet and outlet size. When inlet and outlet sizes are changed or are made smaller, the pump may be damaged and some parts become deformed. In case of this situation, the Manufacturer Company is not responsible for malfunctions and part losses in the pump and pump malfunctions shall not be included within the scope of warranty.



### 1.2.2- Toxic Fluid Hazard

If toxic fluid or fume contacts with eyes or any part of the body during transfer, there may be permanent damages and may cause death risk.

Therefore;

- You should know features of the fluid to be transferred with the diaphragm pump. Take precautions preventing contact of toxic or harmful fluid with environment in parallel with this information.
- Do not move, remove and remove when the diaphragm pump is under pressure in dangerous and toxic fluid transfers.
- Keep dangerous fluid in approved container that fluid will not damage.
- Approach fluid transferred next to diaphragm pump in toxic and dangerous fluid transfers with compatible protective apron, clothes, gloves, goggles and mask.
- Notify absolutely that pumps sent to Gunalsan Pompa and authorized dealer for repair make toxic or dangerous fluid transfer.
- Relieve exhaust air (pressure outlet) of the pumps making toxic fluid transfer to areas that will not damage anything. When diaphragms are exploded, toxic fluid or gas in the pump shall be taken out from pressure outlet.
- Make pipe connections of the pump to which dangerous fluid shall be transferred in a controlled manner.
- Clean these fluids with the fluids that can clean them before transferring toxic, acidic and explosive fluids beforehand and empty fluid in the pump.
- These marks were attached on them while dispatching the pump.

### 1.2.3- Fire and Explosion Hazard

Installation in non-ventilated environments and proper grounding of the pumps that are used in transfer of fluids having fire and explosion danger may cause dangerous situations. In this case, there may be serious injuries or even deaths.



- The pumps transferring inflammable and flammable fluids should be grounded against static electricity. (See Figure 4)

- Do not transfer non-conductor inflammable fluids with non-conductor pump body materials (Polypropylene, PVDF).
- If you encounter any electric shock or sparks while using the pump and equipment, stop the pump. Do not operate the pump without being sure that problem was resolved.
- If fluid transfer is made to the diaphragm pump and it is in a closed environment, ventilate the environment.
- Carry air outlet to a secure environment with pipe. In case of diaphragm explosion, since flammable material will move out with pressurized air, some accidents will be prevented. (See Figure 3)
- Do not smoke in an area where pump is installed and do not use lighter, do not weld.
- The pipe, connected to suction line during inflammable and explosive fluid transfer in diaphragm pump, should not be flexible. Otherwise, vacuum created by the diaphragm pump during suction may cause that pipe bends and it may also stop fluid suction. Besides, there may be tears in the pipe whose surfaces stick together due to vacuum. These tears may cause that inflammable and explosive fluid leaks outside.
- Use protective clothes, protective goggles and face mask in installation or repair of the pump making inflammable and explosive fluid transfer.
- Take necessary safety precautions when inflammable and explosive fluid transfer will be made with the diaphragm pump or transfer fluid temperature is 80°C and above.



**CAUTION** *The pump is delivered to user without equipment. The user is obliged to supply protective equipment and transfer equipment.*



**CAUTION** *Internal parts of the pumps sent to the Manufacturer Company or authorized dealer for service should be emptied in a way not to damage environment and package. The Manufacturer or authorized dealer should be notified about fluid when pumps via which dangerous, explosive, and inflammable fluid hazardous on human health is transferred. The Company using pump is responsible for injuries and even deaths that may occur.*

## 2-Installation

### 2.1- General Information

Installation of the diaphragm pump is easy. However, if installation characteristics recommended by the Manufacturer Company are considered, working life of the pump shall be long and have high efficiency. (See Figure 1).

It should be paid attention that there is no leak and flow from thread connections when air or fluid connection components (hoses, pipes, fittings material and etc.) are interconnected while installing the diaphragm pump. All connection components should be pressurized well. If necessary, fluid seal should be used.

- All bolt and nut connections should be controlled before installing the diaphragm pump and it necessary it should be re-tightened. There may be loosening in these connections due to vibrations that the pump suffered during carrying.

- If there is pressure difference more than 25% between air pressure entering in the diaphragm pump and outgoing fluid pressure, the pump operates inefficiently. Transferred fluid is very dense. This situation may be prevented by increasing weights of balls used as check valve or by using stainless steel marbles.

- Rubber wedge should be placed under pump stands in a place where installation is made while installing the diaphragm pump. This is recommended by the Manufacturer Company. Rubber wedge decreases tensions to pump, prevents dissolution of bolts from vibration and also prevents material fatigue.

- Diaphragm pump installation should be made to fluid to be transferred at a close distance as far as possible.

- Suction line length and fittings number should be kept at a minimum during installation.

- Diameter of suction line of the installed pump should not be decreased to smaller diameters.

- If pipe line is not flexible in a place where diaphragm pump was installed, flexible hose should be positioned between pipe line and pump.

- Our exproof pumps with ATEX Certification are suitable for use in explosive atmospheres.

The following (Figure 1) installation type is to give User Company enlightening information about how installation should be made and to guide. Consult to **Gunalsan POMPA** or authorized dealer for more information and document.

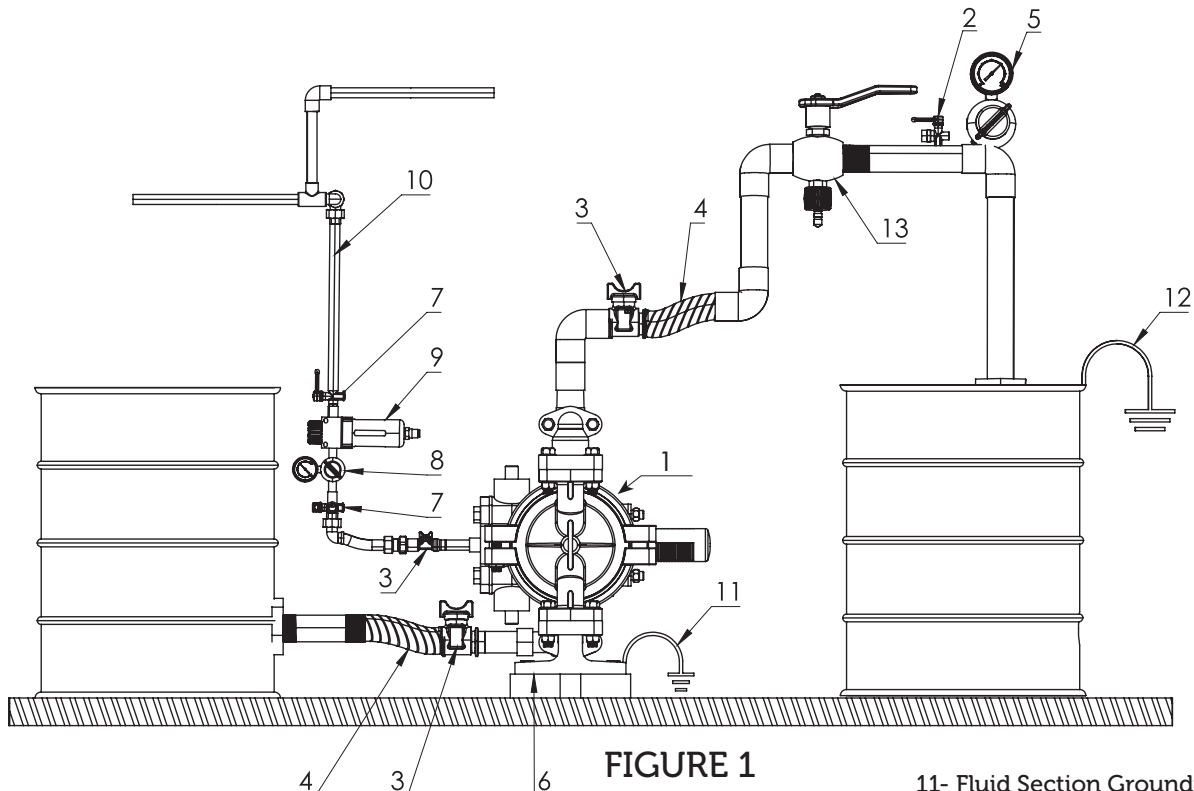

FIGURE 1

- |                                         |                                         |                                                                                                          |
|-----------------------------------------|-----------------------------------------|----------------------------------------------------------------------------------------------------------|
| 1- Aodd Pump                            | 6- Rubber Wedge                         | 11- Fluid Section Grounding Via Grounding Strip or Grounding Screw (Required for Metal and Acetal Pumps) |
| 2- Fluid Relieve Valve                  | 7- Ball Valve (to control air flow)     | 12- Grounding Wire                                                                                       |
| 3- Fluid Shutoff Valve                  | 8- Manometer (air pressure measurement) | 13- Fluid Drain Valve (Required)                                                                         |
| 4- Grounded, Flexible Fluid Outlet Line | 9- Air Filter / Regulator Assembly      |                                                                                                          |
| 5- Manometer                            | 10- Air Supply Line                     |                                                                                                          |

**2.1.1- Secure Operation Temperature for body**

	max.
Polypropylene	65°C
Aluminium	85°C
Stainless Steel	85°C
PVDF	85°C
Cast Iron	85°C
Glass Fiber Reinforced Polypropylene	85°C
Sheet Stainless Steel	85°C

**2.1.2- Secure Operation Temperature for Elastomer Parts**

	max.	min.
<b>Neoprene</b> Its resistance to vegetable oils are very good. Its resistance to abrasion is high. It is preferred to be used in neutral chemicals, grease oils and some solvents. Since Acids, Esters and Ketones damage to material structure, they are unpreferable transfer fluids.	80°C	-23 °C
<b>Buna-n</b> It is generally used in oils. Its use resistance in water and hydraulic oil transfer is high. It can be used easily in fuel and derivatives.	80°C	-23 °C
<b>EPDM</b> Its resistance to chemicals is good. It cannot resist very much towards oil and solvents. Its resistance in alcohols and ketons is at medium level.	85°C	-23 °C
<b>PTFE</b> It is generally used in heavy chemicals and acids. It has great resistance. It is very compatible for fluid transfers in high temperatures.	85°C	-37 °C
<b>Viton</b> Many of solvents and oils have great chemical resistance. It is preferred in hot water and hot solutions in some acids in animal and vegetable oils.	85°C	0 °C
<b>Santoprene</b> It has good resistance to acids and oils. Its mechanical flexibility and flexibility life is long. Abrasion resistance is high.	85°C	-23 °C

**CAUTION** *Temperature values of materials whose operation temperatures are given above are stated by considering use conditions of the diaphragm pump*

**2.2- Air Line**

Pressure from the air line connected to the pump should not exceed 7 bar. Install the air line with a pipe that will not have less size than the connection size so that the pump operates at demanded efficiency. Air line connection size is ¼ in HP 02 type pump. Install air line of the pump as shown in **Figure 1**. Pay attention that air line between the master air line and pump is flexible. Place a cut-off valve (ball valve) before the air line coming to the pump. Close air inlet from this valve when necessary or if pump air is cut off.

- Make air line connection as shown in **Figure 1**. Connect accessories to the wall or to a fixed place. Make sure that air line conducts electricity.

- Place conditioner (air regulator) before air line of the diaphragm pump. Water in pressurized air line may cause frosting or outlet air freezing. This may cause that pump operates in an unbalanced way or it stops completely. Moisture and water in the pressurized air from the compressor may be decreased by being used

with water retainer that may be used in addition to air drying unit of user. This will prevent that polluted air enters in this pump. Besides, it will decrease or prevent freezing in outlet line by keeping a sum of water within line.

- Open air valve approximately between ½ and ¾ to operate the pump. After the pump operates, air flow may be given to air valve at demanded degree. If valve opening increases change frequency but does not increase flow speed, it means that fluid formed a cavitation within suction line. In this case, air coming to valve is decreased and the pump is activated slowly. Thus, cavitation is prevented.

- Fluid flow in the diaphragm pump is controlled in two ways either by controlling pressurized air line entering in the pump with a pressure regulator, ball valve or solenoid valve or by controlling fluid outlet line of the pump with a pressure regulator, ball valve or solenoid valve.



**CAUTION** Air pressurized between air line connected to the diaphragm pump (shown with 3 in Figure 1) should be relieved. Otherwise, pressurized air provides that the pump acts in an unexpected way. This situation may cause accidents and intoxications due to moving parts.

### 2.3- Suction Line

Connection of the pump to master suction line after suction nozzle should be made with flexible hoses. This situation prevents that some parts of the pump are broken during knocking and that bolts are loosened.

- Place cut-off valve before the suction line during installation of the pump. The valve shall provide that pump is removed easily at repair and maintenance times.

- You can observe whether there is regular fluid flow in section line of the pump or not via manometer placed on the line.

- Flexible and master line pipes to be connected to suction line should be conductive. Ground the pipes if you did not use conductive pipes.

- Diaphragm life becomes shorter in fluid inlet pressure higher than 1 bar. The most distinct characteristic of this is that diaphragm life of the diaphragm pumps connected under high tonnage tanks is short due to tank pressure.

- The suction is from the bottom by construction in top check valve diaphragm pumps.

### 2.4- Compression Line

Compression line should be connected to master line with a flexible hose just like suction line so that pipes in the pump are not exposed to knocking, bolts are not dissolved and pump parts are not damaged.

- Place ball cut-off valve before the compression line in a way to be close to the pump. (See Figure 1)

- Place manometer before the compression line to be able to read the pressure. (See Figure 1)

- Flexible and master line pipes to be connected to suction line should be conductive. Ground the pipes if you did not use conductive pipes. (See Figure 1)

- Place fluid Relieve valve or valve to be able to Relieve pressure on the compression line. This valve prevents that harmful fluids are splashed to eyes or skin during Relieve of fluid. It prevents serious injuries. These injuries may cause death.

**CAUTION** Do not tighten connection parts with excessive specified torque during installation. This situation may damage the pump.

### 2.5- Relieve Valve for Fluid Pressure

Expansion of the fluid in compression line by getting heated causes increase of pressure within the line. This situation can be observed in long compression lines with sun effect or environmental factors. Besides, this may occur when valves do not perform their duties in high pressure pumps supported with the diaphragm pump. In these cases, it is recommended to set up pressure relief mechanism as it is seen in Figure 2 (by-pass line).

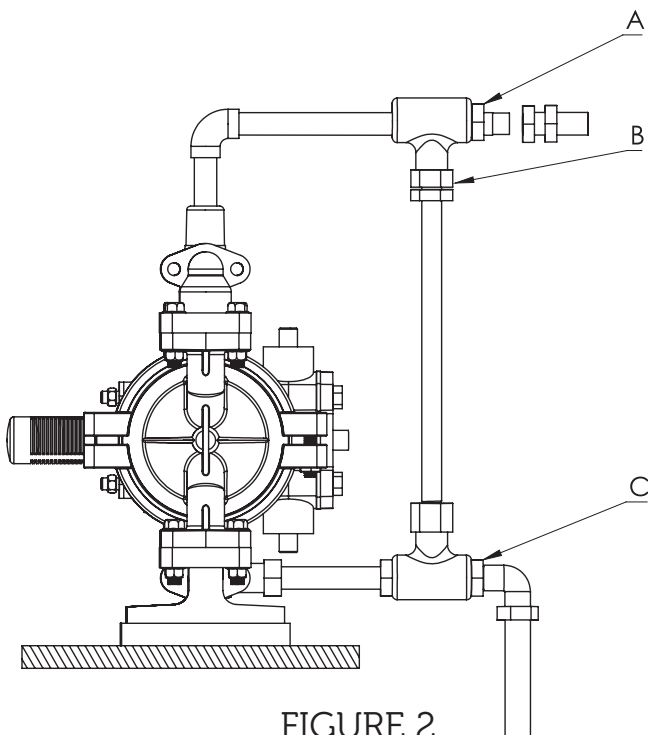

A- Connect fluid outlet line here

B- Install valve between fluid inlet and outlet holes

C- Connect fluid inlet line

FIGURE 2



**CAUTION** *It is recommended to use pressure relief valve in systems where pressure is used in the highest way. This by-pass system will prevent excessive increase of pressure or hose breakdown. (See Figure 2)*

**2.6- Outlet Air Relief**

Environment should be ventilated properly according to system installation type. If the fluid transferred by the pump is toxic, inflammable or explosive, air outlet should be kept off from human, other creatures, areas where food manufacturing is made and all inflammable environments.

- Excessive limit of the air outlet causes ineffective and unbalanced operation of the pump.
- Installation should be made in a way to gather air outlet in a container by considering diaphragm explosion. You can see this in **Figure 3**

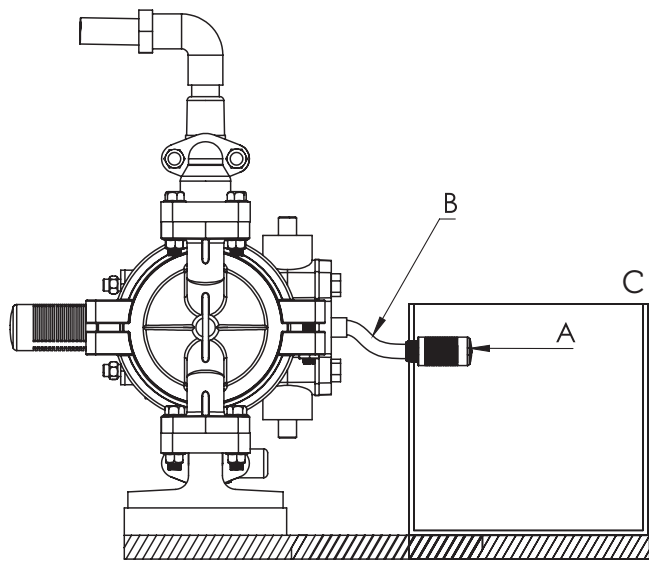

FIGURE 3

- A - Muffler
- B - Electrically Conductive Air Exhaust Hose
- C - Container For Remote Air Exhaust

**2.7- Grounding**

**CAUTION** *Diaphragm Pump should be grounded against the static electricity.*

Ground the diaphragm pump as shown below (**Figure 4**). Surfaces that contact with fluid in the diaphragm pump should be grounded with metal stainless wire or power cable. Suction and compression lines should be selected from the conductive materials while transferring inflammable and explosive fluids. Grounding should be made just like in the pump in two lines. Do not use nonconductive polypropylene and PVDF bodies in inflammable and explosive fluid transfer.

All equipment should be grounded to prevent sparks and fires that may occur due to static electricity and to decrease risks (pump, air and fluid hoses, air compressor, inflammable matter buckets, fluid supply container and etc.).

- Clips should be also grounded in clip type pumps.
- Fluid pressures should be less than  $2 \times 10^{12}$  ohm centimeters in the diaphragm pumps.

**CAUTION** *Grounding cable section should be minimum 6,5 mm in Exproof pumps. Besides, HFFR (Halogen free flame retardant) cable should be used instead of standard cable. Place to which cable to be used in the pump will be connected was stated with a special mark on the pump. The customer supplies this cable.*

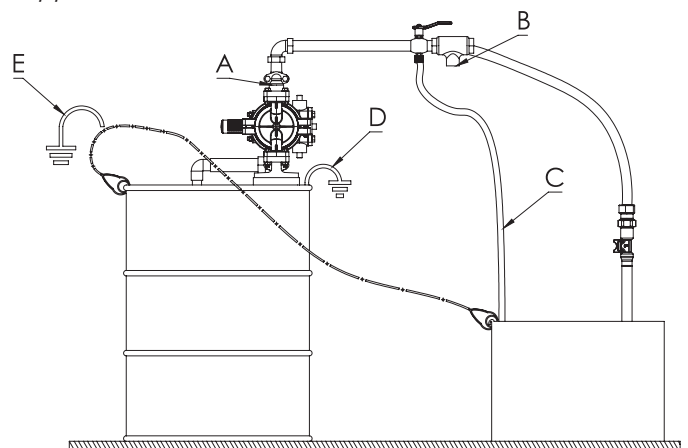

FIGURE 4

- A - AODD Pump
- B - Fluid Relief Valve
- C - Fluid Drain Line
- D - Grounding Strip (Grounding Screw)
- E - Container Grounding Cable

## 2.8- Washing and Cleaning the Pump

The diaphragm pump to be installed was exposed to pressure and leakage test with water by the Manufacturer Company. If any food product will be transferred with this pump or any fluid transfer to react will be made in case of contact with water, wash the pump with a compatible solvent or compatible fluid before commissioning the pump.

## 2.9- Commissioning of the Pump

Connection of the diaphragm pump is very easy. The fluid is absorbed inside the pump from the bottom inlet pipe having suction nozzle and transfer fluid is pressed to outside from the pump from top outlet pipe having pressure nozzle. Diaphragm pumps have a knocking flow. One of the ways to prevent knocking flow is to install flexible hose before inlet and outlet line of the pump in installation place. Another flow regulation is to place damping volume (balance tank, tranquilizer) before the compression line. Manometer and valves are placed to inlet and outlet line to determine pressure values that may occur in inlet and outlet of the pump and to be able to make flow adjustments. When one valve or both valves are closed, the pump does not operate. When both valves are opened, the diaphragm pump continues to operate. The diaphragm pump is not damaged in the meantime.

Pressurized air is needed so that diaphragm pump operates. Air inlet hose should have the same diameter with air inlet line so that the pump operated with full capacity. It is recommended by the Manufacturer Company to place conditioner before the air inlet line. The conditioner controls pressure adjustments and lubricates air diverter valve. Fluid flow rate is adjusted by controlling air flow with valve to be placed before the air inlet line.

Subjects to be considered while installing the diaphragm pump;

- The diaphragm pump should be close to fluid to be transferred as much as possible.
- Suction line length and elbow number in the suction line should be kept minimum as much as possible.
- Inlet-outlet dimension of the diaphragm pump should not be different from connection size in a place where installation was made.

- Pipe connections should be made flexible in a place where the diaphragm pump was installed.
- If the pump does not pull when it is operated, it means cavitation occurred.

Cavitation causes that diaphragm life becomes shorter. Control suction height. Do not operate the pump fast, control suction line diameter. They may cause cavitation.

Control all threaded connections and air connections against leakage and leaks during first commissioning of the pump. If there is any leak, its entering in inflammable, explosive or acidic fluid environment may constitute risk. Damping tanks should be used to prevent knocking in the pipe line in long push distances.

## 2.10- Pressure Equipment Relief

The pump and equipment are under pressure until pressure in the pump is relieved. While the pump is at this stage, the user may be damaged from material to be sprayed, poured or splashed accidentally from the pump or equipment. Apply pressure relief procedure to decrease damage and risks that may be occurred. Situations when pressure relief procedure is applied.

- When you should relief pressure
- When you stop the pump
- When you control, clean or maintain any system equipment.

### How should it be made?

- Close the air line entering in the pump from the valve. Open air pressure relief valve for relieving pressure air remaining between air line valve and pump.
- Close the valve in the push line. Open the valve by opening a compatible container under fluid pressure relief valve. Empty remaining fluid in the container. Remove outlet hose from the pump.

### How is the fluid remaining in the pump emptied?

- Wear clothes compatible for fluid transferred by the pump.
- Close valve, if any, in suction part of the pump.
- Use a compatible container to keep the fluid that will flow or drop from the suction hose.
- Remove the suction hose from suction nozzle. Remove it if it is connected to ground (Figure 5)

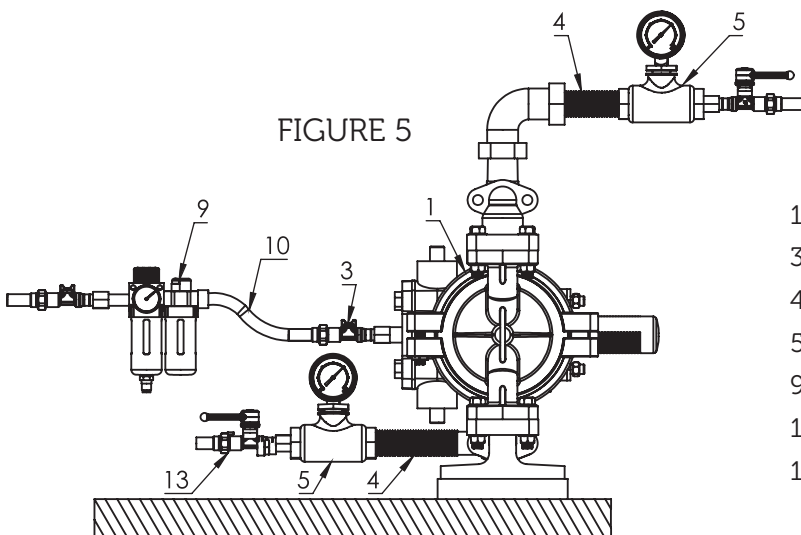

- 1- Diaphragm Pump
- 3- Fluid Cut-off Valve (ball valve)
- 4- Flexible Hose
- 5- Manometer (fluidization measurement)
- 9- Lubricator
- 10- Pressure Line
- 13- Fluid Cut-off Valve (ball valve)

**3-OPERATION**

3.1 Technical Information

3.1.1- Performance Curve and Pump Figure

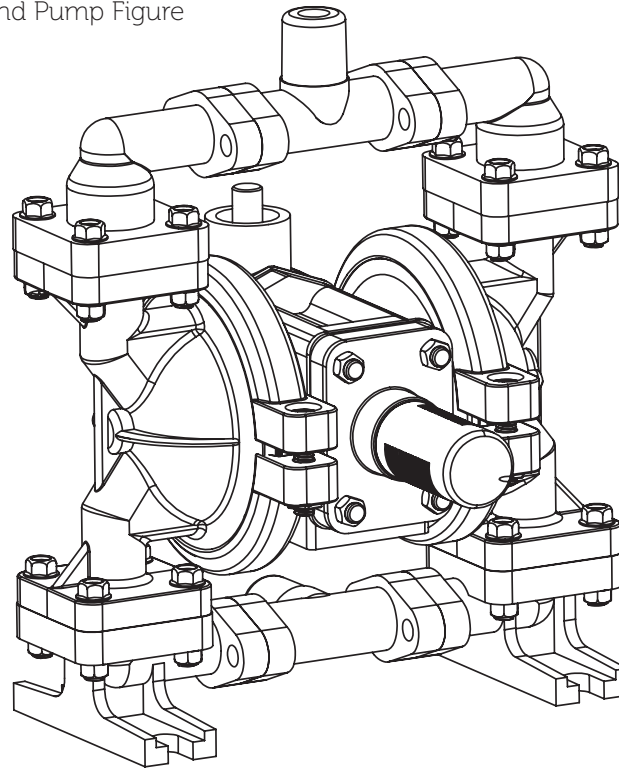

Plastic Body

**Performance Curve of HP 02 (1/4") Diaphragm Pump**

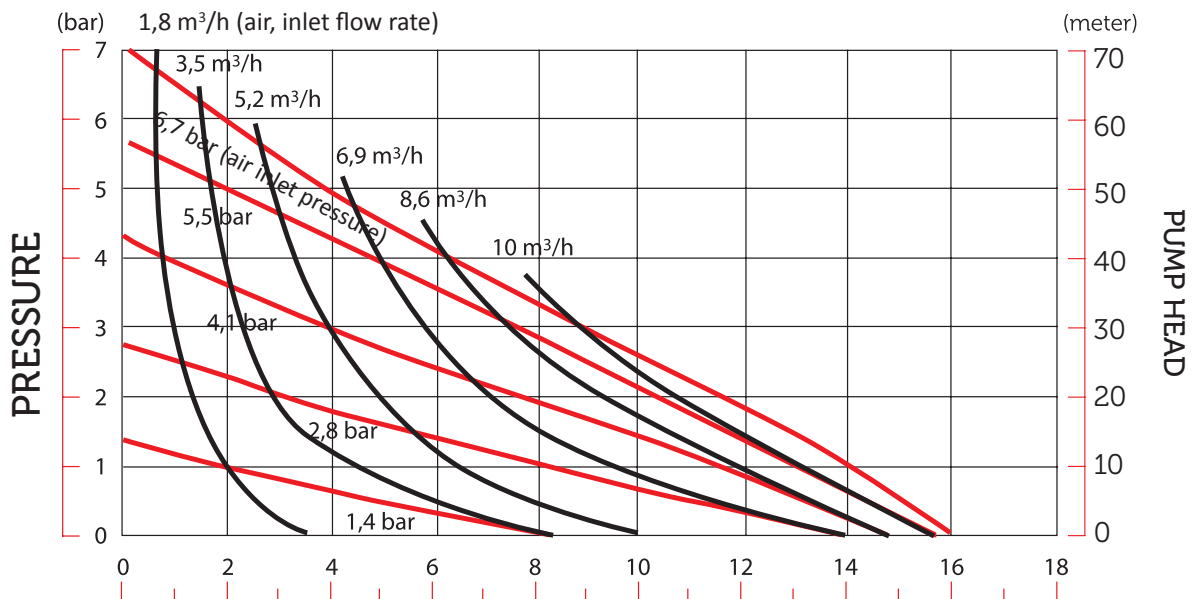

**Capacity in Liter per minute (lt/min.)**

- There may be loss of 25% in pumps whose diaphragm is teflon. The reason is that no supportive diaphragm is used behind teflon diaphragm in the pump. Increase of total hardness in used diaphragm and decrease of pump efficiency.

### 3.1.2- Pump Type Coding

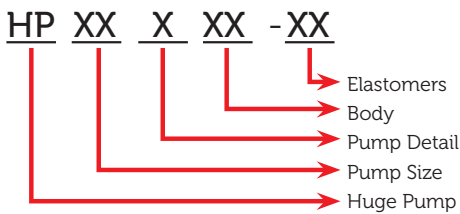
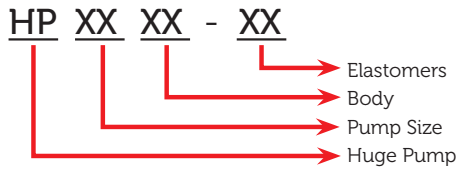

Body	
AL	Aluminium
DD	Cast Iron
SS	Precision Casting
SC	Sheet Stainless Steel
SK	Sand Casting Stainless Steel
PP	Polypropylene
PB	Glass Fiber Reinforced Polypropylene
PVDF	PVDF

Pump Detail	
E	Electrical
T	Dust
C	Dual Outlet
W	All Parts Aluminium

Elastomers		
	Diyaphragm	Ball
N	Neoprene	Neoprene
B	Buna - N	Buna - N
S	Santoprene	Santoprene
E	EPDM	EPDM
T	PTFE	PTFE
V	FKM	FKM
C	-	Steel
TV	PTFE	Viton
TC	PTFE	Steel
TE	PTFE	EPDM
SV	Santoprene	FKM
ST	Santoprene	PTFE
SB	Santoprene	Buna - N
SC	Santoprene	Steel
SN	Santoprene	Neoprene
NC	Neoprene	Steel
BC	Buna - N	Steel

Pump Size	
02	1/4"
05	3/4"
10	1"
15	1 1/2"
20	2"
30	3"

### 3.1.3- Spare Part Type Coding

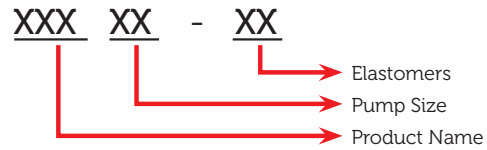

Elastomers	
45	Neoprene
46	Santoprene
47	Buna - N
48	EPDM
50	PTFE
51	FKM
30	Aluminium
31	Casting
32	Stainless
33	Polypropylene
35	PVDF

Pump Size	
02	1/4"
05	3/4"
10	1"
15	1 1/2"
20	2"
30	3"

### 3.1.4- Technical Specifications of the Pump

- Max. Capacity : 16 lt/min.
- Fluid Inlet-Outlet : 1/4"
- Max.Fluid Outlet Pressure : 7 bar
- Pump Head (max) : 70 m
- Body Material : Polypropylene, PVDF
- Diaphragm Options : Santoprene, Neoprene, Buna-N, EPDM, PTFE, FKM
- Top Options : Santoprene, Neoprene, Buna-N, EPDM, PTFE, FKM, Stainless Steel, Steel
- Ball Socket Options : Santoprene, PTFE
- Air inlet Size : 1/4"
- Solid particle Permeability Size: 1 mm
- Dry Suction Depth : 1 m - 1.5 m
- Air Pressure (Min,Max.) : 1-7 bar
- Working Temperature : -18 °C and 100 °C
- Noise Level : 70 dB
- Flow in a stroke : 0,07 lt/min.

\* Our exproof pumps with ATEX Certification are suitable for use in explosive atmospheres.

### 3.1.5- Pump Scaling with Plastic Body

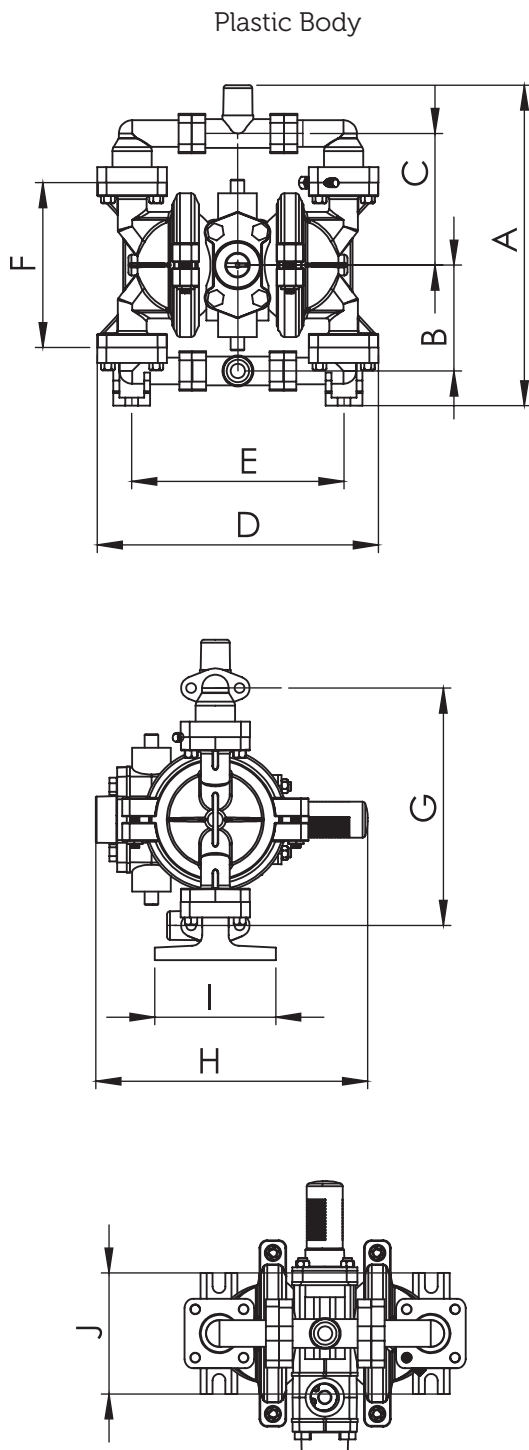

A	B	C	D	E	F	G	H	I	J
212	70	87	186	140	109	157	180	80	80

### 3.1.6- Packaging Sizes and Weights

As it is seen in the following figure, the diaphragm pump is connected to pump fixing board from its stands via bolt and nut. Lean of the pump is prevented during transport.

Scaling with Plastic Body

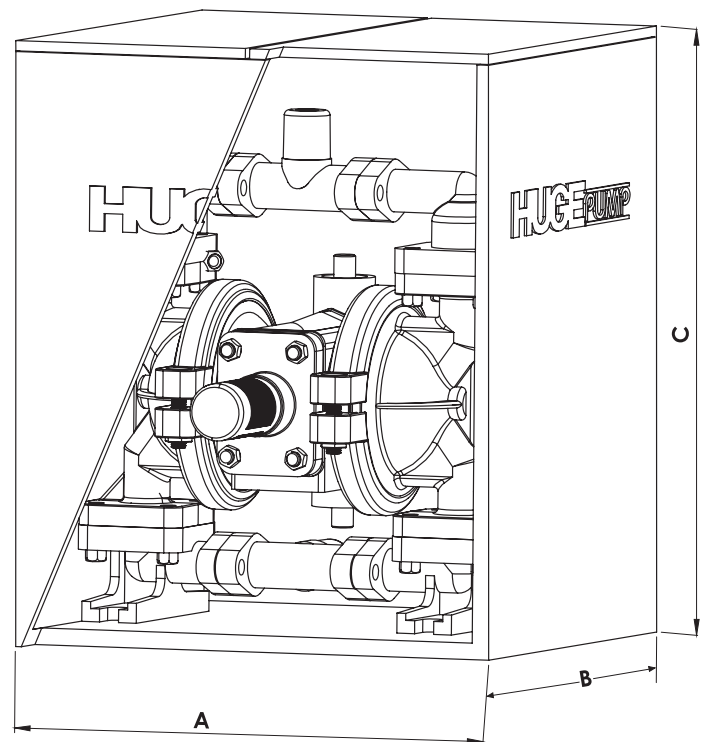

Pump Weight : 1.650 gr  
 Package Weight : 250 gr  
 Gross Weight : 1.900 gr

A	B	C
190	150	230

### 3.1.7- Spare Part Drawing (PLASTIC)

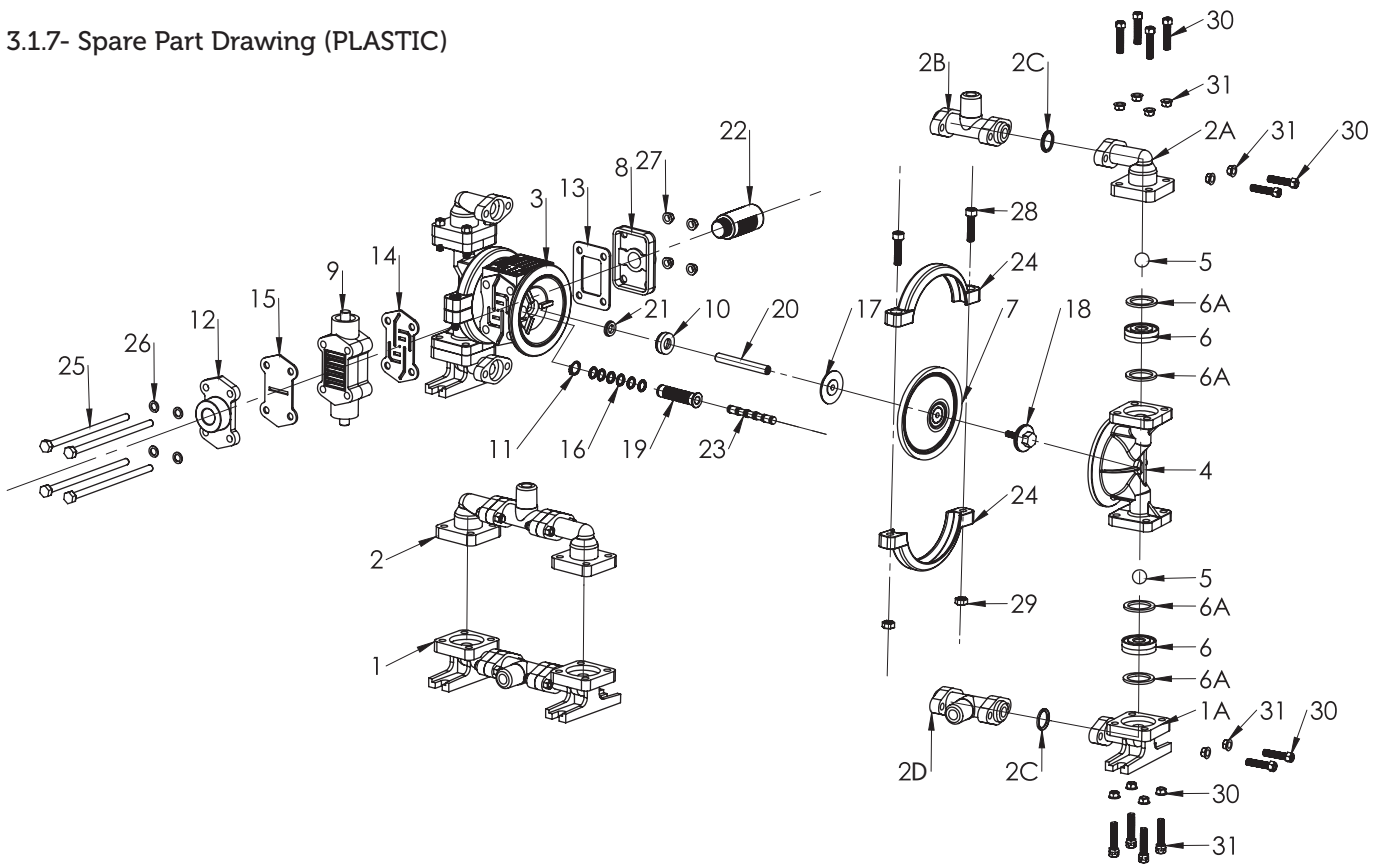

**HP02 PLASTIC BODY PUMP PART LIST**

ITEM NO	PART NUMBER	DESCRIPTION	PIECE	ITEM NO	PART NUMBER	DESCRIPTION	PIECE
1	S010233	SUCTION LINE	1	13	H080247	GASKET,AIR DISCHARGE	1
	S010235	SUCTION LINE	1	14	H090247	GASKET, INTERMEDIATE BRACKET	1
1A	S260233	ELBOW,SUCTION	2	15	H100247	GASKET, VALVE BODY	1
	S260235	ELBOW,SUCTION	2	16	H470247	ORINGS, PILOT VALVE CASE	6
2	S020233	DISCHARGE LINE	1	17	H130230	PLATE,INNER DIAPHRAGM	2
	S020235	DISCHARGE LINE	1	18	S070233	PLATE,OUTHER DIAPHRAGM	2
2A	S600233	ELBOW, DISCHARGE	2		S070235	PLATE,OUTHER DIAPHRAGM	2
	S600235	ELBOW, DISCHARGE	2	19	H460230	SLEEVE, FOR PILOT VALVE	1
2B	S240233	MANIFOLD, VERTICAL	1	20	H150232	SROD,DIAPHRAGM	1
	S240235	MANIFOLD, VERTICAL	1	21	H160247	OIL SEAL	2
2C	S160246	SEAL,MANIFOLD	4	22	H179033B	MUFFLER	1
2D	S240233D	MANIFOLD, HORIZONTAL (OPTIONAL DISCHARGE)	1	23	H480232	SPOOL,PILOT VALVE	1
	S240235D	MANIFOLD, HORIZONTAL (OPTIONAL DISCHARGE)	1	24	H200232	CLAMP	2
3	H010233B	MAIN BODY	1	25	CM6X115	CAPSCREW HEX HEAD M6x115 LONG	4
4	S030233	CHAMBER OUTER	2	26	PM6-P	WASHER M6 STAINLESS	4
	S030235	CHAMBER OUTER	2	27	SM6-PF	NUT HEX FLANGE M6 STAINLESS	4
5	S040245	BALL,CHECK	4	28	CM6X35-PI	CAPSCREW SOC HEAD M6x35	4
	S040246	BALL,CHECK	4	29	SM6	NUT HEX M6	4
	S040247	BALL,CHECK	4	30	CM5X25-P	CAPSCREW HEX HEAD M5x25 STAINLESS	24
	S040248	BALL,CHECK	4	31	SM5-PF	NUT HEX M5 STAINLESS	24
	S040250	BALL,CHECK	4				
	S040251	BALL,CHECK	4				
6	S050233	BALL SEAT	4				
	S050235	BALL SEAT	4				
6A	S080246	GASKET,BALL SEAT	8				
7	S060245	DIAPHRAGM	2				
	S060246	DIAPHRAGM	2				
	S060247	DIAPHRAGM	2				
	S060248	DIAPHRAGM	2				
	S060250	DIAPHRAGM	2				
	S060251	DIAPHRAGM	2				
8	H180233B	CAP, AIR INLET EXHAUST	1				
9	H030233B	AIR VALVE BODY	1				
10	S130233	BUMPER	2				
11	S120290	RING RETAINING, FOR PILOT VALVE	2				
12	H070233B	CAP, AIR INLET	1				



## 4- MAINTENANCE

If fluid to be transferred before starting pump maintenance has freezing and drying characteristic, it should be cleaned with proper cleaning fluid. Otherwise, pump maintenance will be more expensive and difficult. Control bolt connections in each use. Tighten loose connections with key. Replace necessary connections.

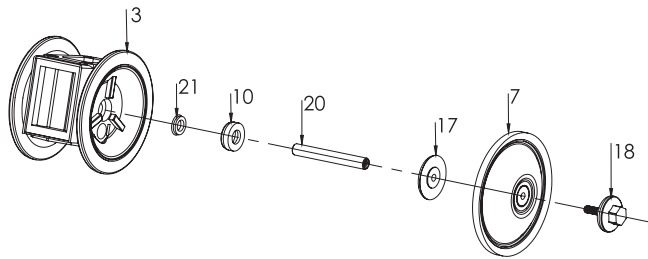

### 4.1 – Diaphragm Maintenance

Line	Part No	Part Name
3	H010233B	Main Body
21	H160247	Oil Seal
10	S130233	Bumper
20	H150232	Srod, Diaphragm
17	H130230	Plate, Inner Diaphragm
7	S0602XX	Diaphragm
18	S070233	Plate, Outer Diaphragm

**CAUTION** *Double diaphragm is used with options of teflon diaphragm pump. Rubber diaphragm that is used before the teflon provides that teflon diaphragm is long-lived by extending its fracture and fatigue strength.*

Firstly close pump suction line and then pump Outlet line to maintain the diaphragm. Relieve pressure in the pump after closing pressure air and remove the pump from air inlet line. Empty the fluid in the pump. See pump installation figures and diaphragm maintenance schemes. Remove suction and push lines. Remove ball and ball slots. Then, remove external covers of the pump.

#### 4.1.1- Removal of the Diaphragm

Remove external diaphragm fastener by turning it counter-clockwise via use of 12 socket wrench to remove diaphragm group from diaphragm shaft. One of the diaphragm shall be removed with internal and external diaphragm fastener and the other shall be removed in a way to be connected to shaft. Firstly, connect the internal diaphragm fastener to clamp to remove the diaphragm between internal and external diaphragm fastener and tighten it, and remove it by turning it counter-clockwise via use of 12 socket wrench.

Fasten the shaft connected to other diaphragm to the clamp loosely and remove it via use of wrench. Repeat the same operation to remove other diaphragm. Control the diaphragm for cut, puncture, wear and chemical exposure.

#### 4.1.2- Installation of the Diaphragm

Fasten external diaphragm to fastener and push from central hole of the diaphragm to inside. Tighten the internal diaphragm to the shaft clockwise by installing bolt. Re-install loose group to the clamp. Tighten diaphragm group with 12 socket wrench.

#### 4.1.3- Installation of the Diaphragms to the Pump

Make sure that ram was installed on the diaphragm shaft. Tighten a diaphragm group shaft until it comes to same line with shaft end of internal diaphragm plate to threaded hole on diaphragm end clockwise. Install the shaft to the pump. Align bolt holes in the diaphragm with bolt holes of internal chamber. Connect external chamber to the pump by using bolt and nut.

Pull diaphragm shaft from other side of pump as well as that it comes. Make sure that ram is installed on diaphragm shaft. Tighten open shaft of the diaphragm group to the diaphragm shaft clockwise as much as possible and leave a blank in a way to make adjustment so that bolt holes in the diaphragm coincides with internal chamber bolt holes.

Install suction and push lines to the pump by using bolt, nut and washer. Connect the suction and push lines to the pump by using bolt, nut and washer. The pump is ready to be re-fastened and used.

## 4.2– Air Valve Kit Types and Maintenance

Air valves are lubricated with special greases in the factory so that there is no additional lubrication requirement. If additional lubrication is demanded, air valve connected to the pump is removed in 1 or 2 weeks. Machine oil is added to inside 4-5 times with an oil feeder

### H030233B Air Valve Repair Kit

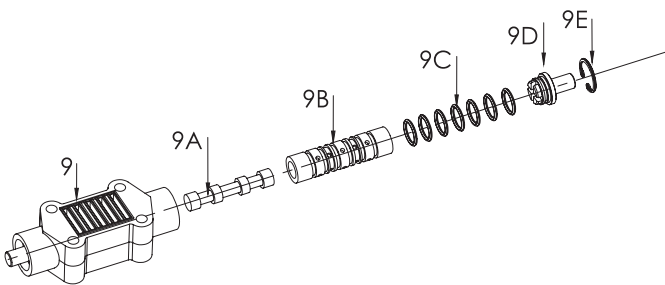

#### AIR VALVE (PLASTIC BODY) REPAIR KIT PART LIST

Line	Part No	Part Name
9	H550233	Air Valve Body
9A	H720270	Spool, Air Valve
9B	H710270	Sleeve, Air Valve
9C	H579047	Orings, Air Valve
9D	H580233	Cap, End
9E	H509090	Ring, Retaining

### H590232 Sleeve - Spool Set

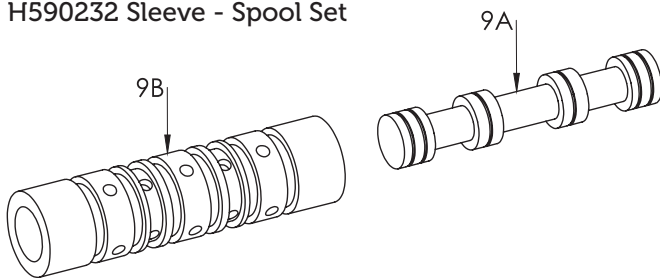

#### CASE PISTON REPAIR KIT PART LIST

Line	Part No	Part Name
9A	H720270	Spool, Air Valve
9B	H710270	Sleeve, Air Valve

**CAUTION** Do not lubricate the pump excessively while making extra lubrication. This situation may cause pollution around and even malfunction.

## 4.3– Pilot Valve Repair Kit Types and Maintenance

Close suction and push line of the pump before starting valve maintenance. Cut pressure air inlet and relieve pressure in the pump. Relieve fluid in the pump.

### H040233B Pilot Valve Repair Kit

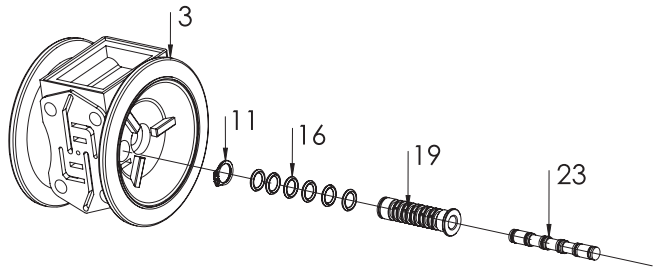

#### PILOT VALVE REPAIR KIT PART LIST

Line	Part No	Part Name
3	H010233B	Main Body
11	S120290	Ring Retaining, for Pilot Valve
16	H470247	Orings, for Pilot Valve Case
19	H460230	Sleeve, for Pilot Valve
23	H480232	Spool, Pilot Valve

See pump installation figures.

Remove four bolts by using wrench or socket. Remove air inlet cover and air inlet gasket. Pilot valve group can be removed for control and maintenance. You can remove pilot valve kit before removing the pump completely.

Remove pilot valve piston. Clean and control piston and o-rings for dirt, cut and wear. When necessary, replace o-rings and piston with new ones. Remove the segment from case end and case from the valve body and clean. Control case and o-rings for dirt, cut and wear. When necessary, replace o-rings and case with new ones.

Lubricate external surface and o-rings of the case abundantly. Then place the case in valve body carefully. PAY ATTENTION that o-rings are not cut while placing the case. Install the segments in case. Lubricate external surface and o-rings of the case abundantly. Then place the case in valve body carefully. PAY ATTENTION that o-rings are not cut while placing the case.

Pay attention that pilot valve ends are adjusted between piston pins while reinstalling pilot valve group to intermediate space gap. Reinstall gasket, air inlet cover and bolts. Connect air inlet to the pump. The pump is ready to be used.

#### 4.4- Plastic Body Pump Check Valve Maintenance

Close suction and push line of the pumps before starting check valve maintenance. Cut pressure air inlet and relieve pressure in the pump. Relieve fluid in the pump. Remove the bolts in fluid inlet and fluid Outlet lines in section shown in the figure and achieve ball valve. Control tear, wear and cuts that may occur in global surface of the balls. Ball slots should be controlled in terms of potential materials adherent on internal and external surfaces for cut and wear. Ball surfaces should be placed completely on surfaces of the ball slots. This situation affects pump efficiency. When necessary, replace wearing or damaged parts. Regroup check valve parts.

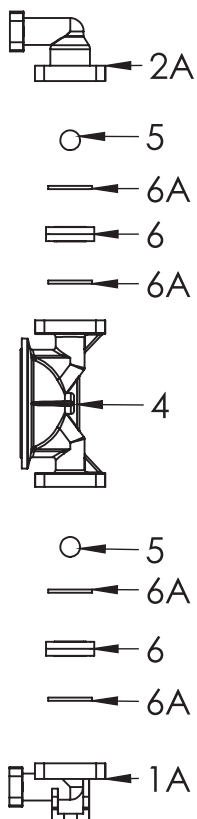

Line	Part No	Part Name
1A	S260233	Elbow, Suction
	S260233	Elbow, Suction
6A	S080246	Gasket, Ball, Seat
6	S0502xx	Ball Seat
5	S0402xx	Ball, Check
4	S030233	Chamber Outher
	S030235	Chamber Outher
2A	S600233	Elbow, Discharge
	S600235	Elbow, Discharge

**CAUTION** Feeders in external cover and Outlet manifolds should be controlled in abrasive fluid transfers during ball valve change. This may wear fluid feeders and cause that balls are ruptured.

#### 4-5 – Torque Line in Plastic Body Pumps

##### AIR VALVE COVER

Tighten the bolts with 6N.m\_9N.m torque

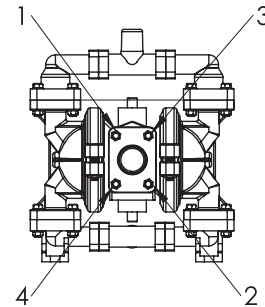

##### T ELBOW PART

Tighten the bolts with 6N.m\_10N.m torque

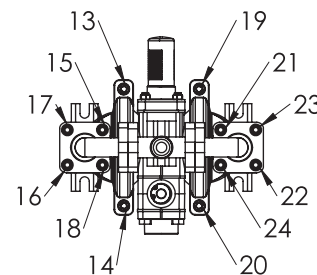

##### PILOT VALVE COVER

Tighten the bolts with 6N.m\_9N.m torque

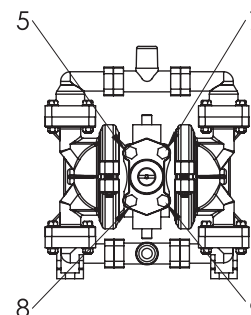

##### RIGHT-LEFT FLUID COVER

Tighten the bolts with 6N.m\_10N.m torque

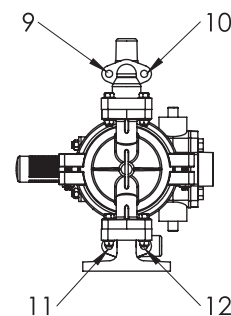

## 4.6- PROBLEMS THAT MAY OCCUR IN THE PUMP AND THEIR SOLUTIONS

If pressure air comes to the pump and pump does not operate, air directly gets out from the exhaust.	The case piston may be stuck. Air coming to the pump should be clean.	Remove and clean air valve
If the pump operates but does not suction	Parts may be pressurized between ball and ball slot.	Clean ball valves especially in suction section.
If the pump operates but fluid capacity is low	Air coming from the compressor may be less. Ball and ball slots may be abraded.	Control and if necessary replace with the new ones.
If pump transfer is unbalanced	Pilot valve may be malfunctioned	Replace with the new one
If there are bubbles in fluid coming from the pump	Suction line may be loose.	Compress
	Diaphragm may be perforated.	Replace
	Diaphragm retainers may be loose.	Compress
If liquid comes from the exhaust air	Diaphragm may be perforated.	Replace
	Diaphragm retainers may be loose.	Compress
	Compressor air is excessively moist.	Clean compressor tank.

## 5- WARRANTY CONDITIONS

Gunalsan gives warranty to remove material and workmanship defects arising from production as of the date when pumps with HUGE brand that it produces are sold to final user. This warranty applies only when the equipment is installed, operated and maintained in accordance with Gunalsan's written recommendations.

This warranty does not include general wear and tear and Gunalsan/HUGE general wear and tear or faulty installation, faulty application, abrasion, corrosion, inadequate or improper maintenance, negligence, accident, unconscious maintenance or equipment not included within warranty of Gunalsan/ HUGE: (hoses, connection components, pneumatic regulator.) diaphragms having consumables, check valve balls, ball slots and all the bolts (o-ring, z-ring) are not within the scope of warranty.

It does not give any warranty for accessories and equipment which are sold by Gunalsan but not produced by it and rejects warranties fitting for all old merchantability and a definite purpose.

In no event, Gunalsan/HUGE accepts any compensation, loss, damage and injury responsibility under no circumstances, does not accept any responsibility, liability, cost or expenditure that are directly or indirectly related to or occur due to use or non-functionality of any product or Gunalsan/HUGE does not accept any responsibility or liability regarding direct, special, criminal or successive results including but not limited to sales loss, profit loss, pumped material loss, work slowdown, production loss, contract loss, reputation or good will injury whether Gunalsan/HUGE is aware of or notified about potential damages.

This warranty is conditioned upon sending the pump inner as completely emptied and cleaned in a way not to damage the environment and package by paying transportation fee to Gunalsan or authorized distributor to verify equipment stated to be defective and notified malfunction.

Equipment shall be returned to final user as prepaid transportation fee. If there is no material or labor fault as a result of equipment examination, repair operation shall be made against a reasonable price that may include part, labor and transport costs.

Gunalsan/HUGE web site, introduction marketing and technical literature and declarations and data on materials are not intentional for defining performance under real use conditions of any product or at a time when it was used in special applications, they do not define warranty, and these declarations and data should not be relied in determination of compliance of the products for performance or special applications under real use conditions.

All decisions on inefficiency reason depend only on Gunalsan Pompa's determination. Prior approval should be received from Gunalsan to give back any product so as to make evaluation on scope of the warranty.

In any case, Gunalsan/HUGE responsibility regarding any single product shall be limited to original price paid for the product.

No Gunalsan/HUGE authorized distributor or any other person is authorized to make any amendment on product warranty and expose Gunalsan/HUGE apart from those submitted here expressly to any responsibility or liability.

### Extended Product Warranty

Pumps, produced with Gunalsan/HUGE pump brand, are warranted against labor and fabrication faults for 2 years as of invoice date.

Repair period of the pumps is 20 business days, our Company is not responsible for the products not delivered within 60 days. Period elapsed in repair is within the warranty period. In case of conflict, consumer has liability to prove.

5 years: Gunalsan gives warranty on spare part and labor supply.

5-10 years: Gunalsan gives only warranty on supplying spare part.

All written and visual data in this document reflect last product information current while they were printed. Gunalsan reserves the right to make amendment without making prior notification at any time.

### GUNALSAN POMPA ve MAK. SAN. TIC. LTD. STI.

Maltepe Mah. Ciftehavuzlar Cad.

Ayvalidere Sok. No: 6 Zeytinburnu / Istanbul

☎ 0212 613 41 42 📠 0212 613 41 49

✉ satis@gunalsanpompa.com

www.gunalsanpompa.com

**HUGE** **PUMP**

**HP02**