



HUGE FLUID SOLUTIONS



HUGE PUMP



*METALLIC BODY
DIAPHRAGM PUMPS*







HP05 ATEX METALLIC BODY PUMP

HUGEPUMP



APPLICATION AREAS

-  WASTE WATER TREATMENT
-  MINING - ENERGY
-  TEXTILE
-  MARINE
-  PACKAGING
-  MACHINE-AUTOMATION
-  CHEMICAL INDUSTRY
-  AUTOMOTIVE
-  FOOD INDUSTRY
-  PAINT INDUSTRY

ADVANTAGES

- 1) Solid particles may pass through the pump.
- 2) The pump is ex-proof. (Suitable for explosive and flammable fluids.)
- 3) Maintenance cost is low.
- 4) Liquid flow rate can also be adjusted when the air inlet pressure of the pump is adjusted.
- 5) The pump's air valve and pilot valve repair kits can be repaired without disassembling the pump.
- 6) It has the feature of working dry.
- 7) The suction depth of this pump is 6 m.

PUMP TECHNICAL SPECIFICATIONS

- Max. Capacity** : 55 l/min
- Fluid Inlet-Outlet** : 3/4"
- Max. Fluid Discharge** : 7 bar
- Body Material** : Aluminum, Casting, Stainless Steel
- Air Inlet Size** : 1/4"
- Solid Particle Size** : 3 mm
- Dry Suction Depth** : 6 m
- Max Air Pressure** : 7 bar
- Diaphragm Options** : Santoprene, Neoprene, Buna-N, EPDM, Teflon, Viton
- Ball Options** : Santoprene, Neoprene, Buna-N, EPDM, Teflon, Viton
- Ball Seat Options** : Santoprene, Neoprene, Buna-N, EPDM, Teflon, Viton



Ex h IIB T(80°C) Gb
Ex h IIIB T(80°C) Db
Ex h I M2 T(80°C) Mb

Note: The valve parts of the pumps are made of conductive polypropylene.

DIAPHRAGM PUMPS PERFORMANCE CURVES

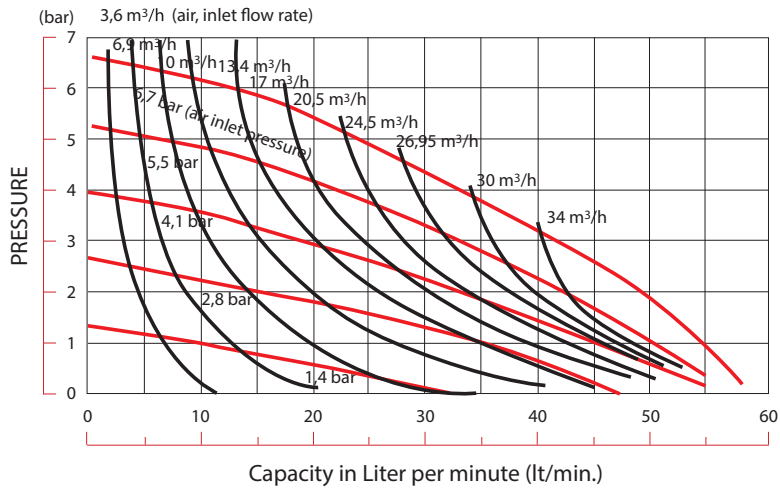

PUMP EXTERNAL DIMENSIONS

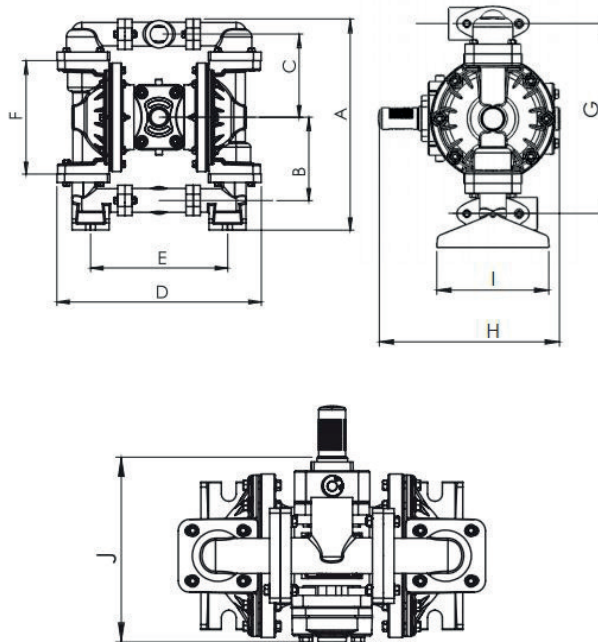

A	B	C	D	E	F	G	H	I	J
279	110	110	270	181	150	220	209	130	163

HP10 ATEX METALLIC BODY PUMP

HUGEPUMP



APPLICATION AREAS

- WASTE WATER TREATMENT
- TEXTILE
- PACKAGING
- AUTOMOTIVE
- FOOD INDUSTRY
- PAINT INDUSTRY
- MINING - ENERGY
- MARINE
- MACHINE-AUTOMATION
- DEFENSE INDUSTRY
- PETROL AND OIL
- CERAMIC INDUSTRY
- MEDICAL INDUSTRY

ADVANTAGES

- 1) Solid particles may pass through the pump.
- 2) The pump is ex-proof. (Suitable for explosive and flammable fluids.)
- 3) Maintenance cost is low.
- 4) Liquid flow rate can also be adjusted when the air inlet pressure of the pump is adjusted.
- 5) The pump's air valve and pilot valve repair kits can be repaired without disassembling the pump.
- 6) It has the feature of working dry.
- 7) The suction depth of this pump is 6 m.



Ex h IIB T(80°C) Gb
Ex h IIIB T(80°C) Db
Ex h I M2 T(80°C) Mb

PUMP TECHNICAL SPECIFICATIONS

- Max. Capacity** : 150 l/min
- Fluid Inlet-Outlet** : 1"
- Max. Fluid Discharge** : 7 bar
- Body Material** : Aluminum, Casting, Stainless Steel
- Air Inlet Size** : ½"
- Solid Particle Size** : 4 mm
- Dry Suction Depth** : 6 m
- Max Air Pressure** : 7 bar
- Diaphragm Options** : Santoprene, Neoprene, Buna-N, EPDM, Teflon, Viton
- Ball Options** : Santoprene, Neoprene, Buna-N, EPDM, Teflon, Viton
- Ball Seat Options** : Santoprene, Neoprene, Buna-N, EPDM, Teflon, Viton

Note: The valve parts of the pumps are made of conductive polypropylene.

DIAPHRAGM PUMPS PERFORMANCE CURVES

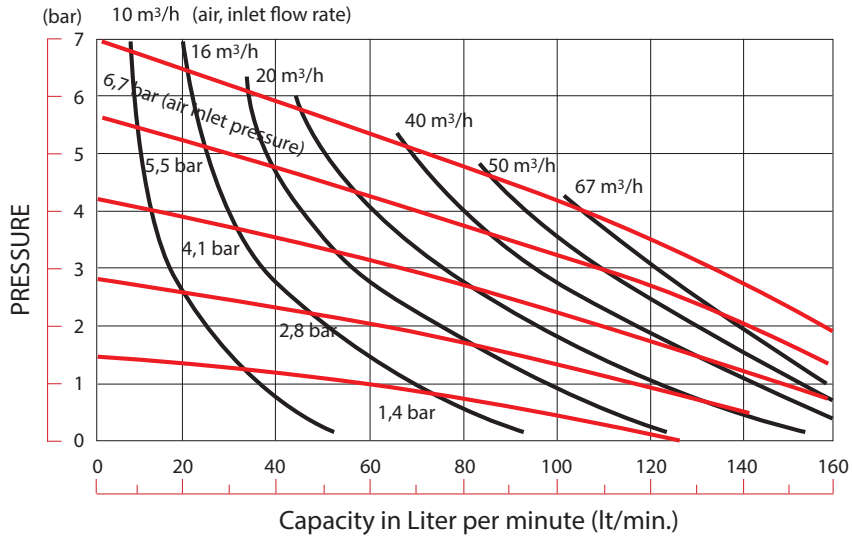

PUMP EXTERNAL DIMENSIONS

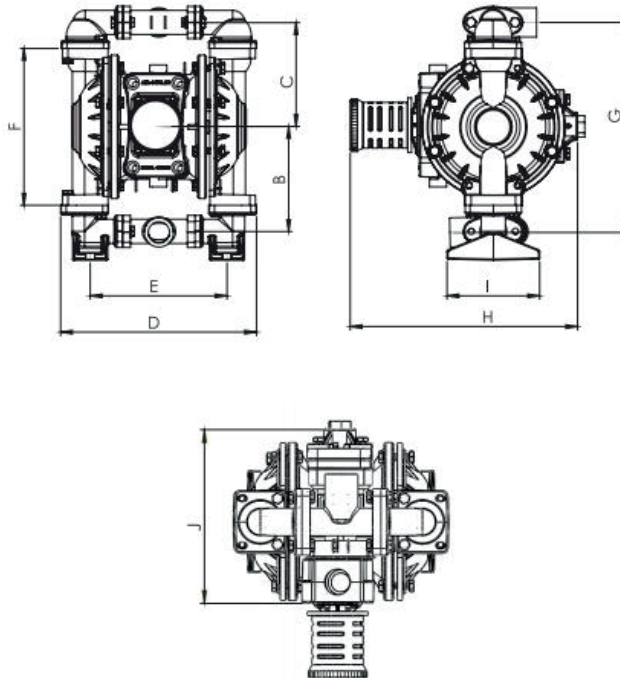

A	B	C	D	E	F	G	H	I	J
356	146	146	274	191	220	293	312	130	220

HP15 ATEX METALLIC BODY PUMP

HUGEPUMP



APPLICATION AREAS

- WASTE WATER TREATMENT
- TEXTILE
- PACKAGING
- AUTOMOTIVE
- FOOD INDUSTRY
- PAINT INDUSTRY
- MINING - ENERGY
- MARINE
- MACHINE-AUTOMATION
- DEFENSE INDUSTRY
- PETROL AND OIL
- CERAMIC INDUSTRY
- MEDICAL INDUSTRY

ADVANTAGES

- 1) Solid particles may pass through the pump.
- 2) The pump is ex-proof. (Suitable for explosive and flammable fluids.)
- 3) Maintenance cost is low.
- 4) Liquid flow rate can also be adjusted when the air inlet pressure of the pump is adjusted.
- 5) The pump's air valve and pilot valve repair kits can be repaired without disassembling the pump.
- 6) It has the feature of working dry.
- 7) The suction depth of this pump is 6 m.

PUMP TECHNICAL SPECIFICATIONS

- Max. Capacity** : 400 l/min
- Fluid Inlet-Outlet** : 1½"
- Max. Fluid Discharge** : 7 bar
- Body Material** : Aluminum, Casting, Stainless Steel
- Air Inlet Size** : 3/4"
- Solid Particle Size** : 6 mm
- Dry Suction Depth** : 6 m
- Max Air Pressure** : 7 bar
- Diaphragm Options** : Santoprene, Neoprene, Buna-N, EPDM, Teflon, Viton
- Ball Options** : Santoprene, Neoprene, Buna-N, EPDM, Teflon, Viton
- Ball Seat Options** : Santoprene, Neoprene, Buna-N, EPDM, Teflon, Viton



Ex h IIB T(80°C) Gb
Ex h IIIB T(80°C) Db
Ex h I M2 T(80°C) Mb

Note: The valve parts of the pumps are made of conductive polypropylene.

DIAPHRAGM PUMPS PERFORMANCE CURVES

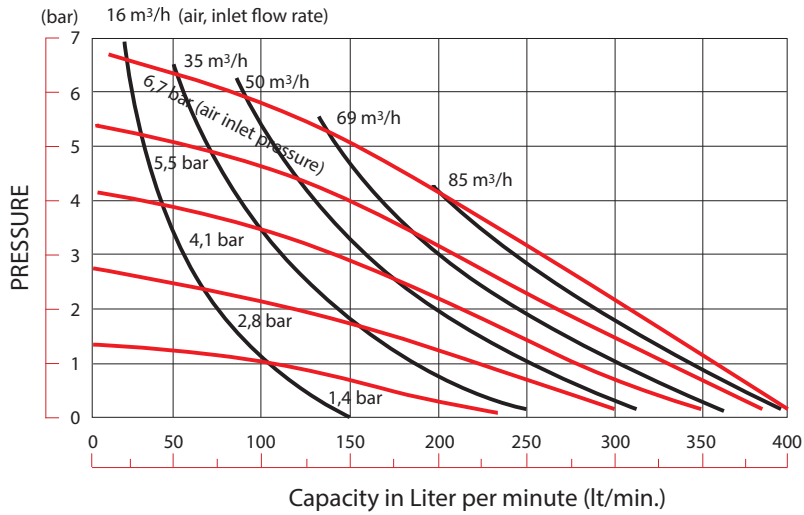

PUMP EXTERNAL DIMENSIONS

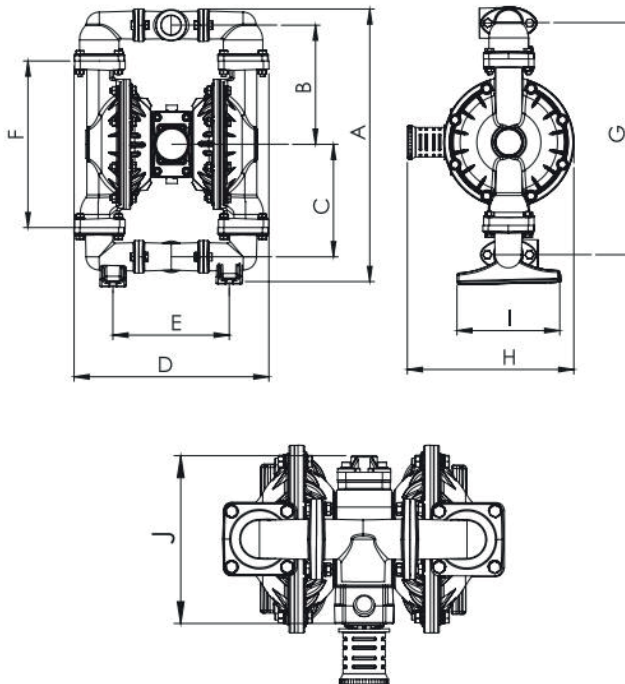

A	B	C	D	E	F	G	H	I	J
605	260	245	425	253	363	505	363	224	253



APPLICATION AREAS

-  WASTE WATER TREATMENT
-  MARINE
-  TEXTILE
-  MACHINE-AUTOMATION
-  PACKAGING
-  DEFENSE INDUSTRY
-  AUTOMOTIVE
-  PETROL AND OIL
-  FOOD INDUSTRY
-  CERAMIC INDUSTRY
-  PAINT INDUSTRY
-  MEDICAL INDUSTRY
-  MINING - ENERGY

ADVANTAGES

- 1) Solid particles may pass through the pump.
- 2) The pump is ex-proof. (Suitable for explosive and flammable fluids.)
- 3) Maintenance cost is low.
- 4) Liquid flow rate can also be adjusted when the air inlet pressure of the pump is adjusted.
- 5) The pump's air valve and pilot valve repair kits can be repaired without disassembling the pump.
- 6) It has the feature of working dry.
- 7) The suction depth of this pump is 6 m.

PUMP TECHNICAL SPECIFICATIONS

- Max. Capacity** : 560 l/min
- Fluid Inlet-Outlet** : 2"
- Max. Fluid Discharge** : 7 bar
- Body Material** : Aluminum, Casting, Stainless Steel
- Air Inlet Size** : 3/4"
- Solid Particle Size** : 6 mm
- Dry Suction Depth** : 6 m
- Max Air Pressure** : 7 bar
- Diaphragm Options** : Santoprene, Neoprene, Buna-N, EPDM, Teflon, Viton
- Ball Options** : Santoprene, Neoprene, Buna-N, EPDM, Teflon, Viton
- Ball Seat Options** : Santoprene, Neoprene, Buna-N, EPDM, Teflon, Viton



Ex h IIB T(80°C) Gb
 Ex h IIIB T(80°C) Db
 Ex h I M2 T(80°C) Mb

Note: The valve parts of the pumps are made of conductive polypropylene.

DIAPHRAGM PUMPS PERFORMANCE CURVES

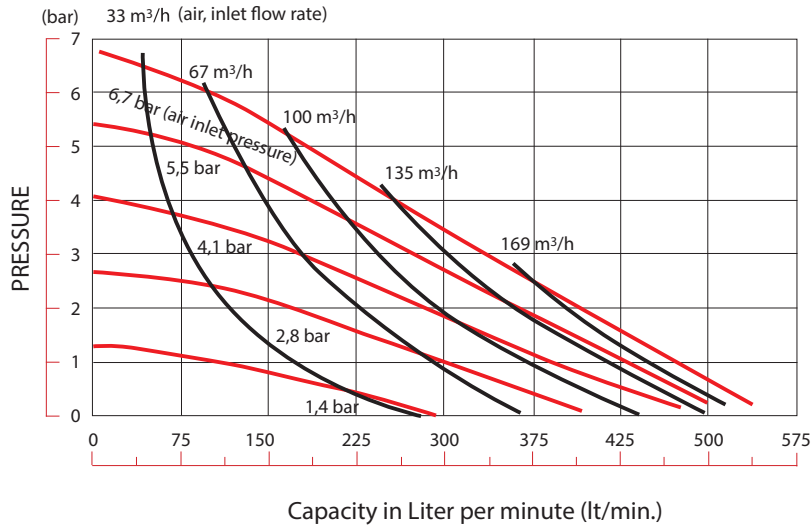

PUMP EXTERNAL DIMENSIONS

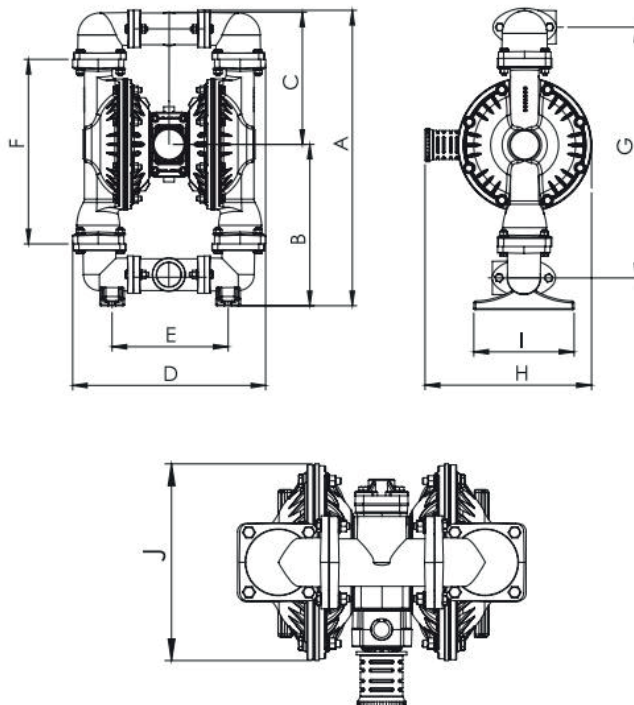

A	B	C	D	E	F	G	H	I	J
669	365	299	438	263	418	556	370	223	298

HP30 ATEX METALLIC BODY PUMP

HUGEPUMP



APPLICATION AREAS

- WASTE WATER TREATMENT
- TEXTILE
- PACKAGING
- AUTOMOTIVE
- FOOD INDUSTRY
- PAINT INDUSTRY
- MINING - ENERGY
- MARINE
- MACHINE-AUTOMATION
- DEFENSE INDUSTRY
- PETROL AND OIL
- CERAMIC INDUSTRY
- MEDICAL INDUSTRY

ADVANTAGES

- 1) Solid particles may pass through the pump.
- 2) The pump is ex-proof. (Suitable for explosive and flammable fluids.)
- 3) Maintenance cost is low.
- 4) Liquid flow rate can also be adjusted when the air inlet pressure of the pump is adjusted.
- 5) The pump's air valve and pilot valve repair kits can be repaired without disassembling the pump.
- 6) It has the feature of working dry.
- 7) The suction depth of this pump is 6 m.

PUMP TECHNICAL SPECIFICATIONS

- Max. Capacity** : 890 l/min
- Fluid Inlet-Outlet** : 3"
- Max. Fluid Discharge** : 7 bar
- Body Material** : Aluminum, Casting, Stainless Steel
- Air Inlet Size** : 3/4"
- Solid Particle Size** : 8 mm
- Dry Suction Depth** : 6 m
- Max Air Pressure** : 7 bar
- Diaphragm Options** : Santoprene, Neoprene, Buna-N, EPDM, Teflon, Viton
- Ball Options** : Santoprene, Neoprene, Buna-N, EPDM, Teflon, Viton
- Ball Seat Options** : Santoprene, Neoprene, Buna-N, EPDM, Teflon, Viton



Ex h IIB T(80°C) Gb
Ex h IIIB T(80°C) Db
Ex h I M2 T(80°C) Mb

Note: The valve parts of the pumps are made of conductive polypropylene.

DIAPHRAGM PUMPS PERFORMANCE CURVES

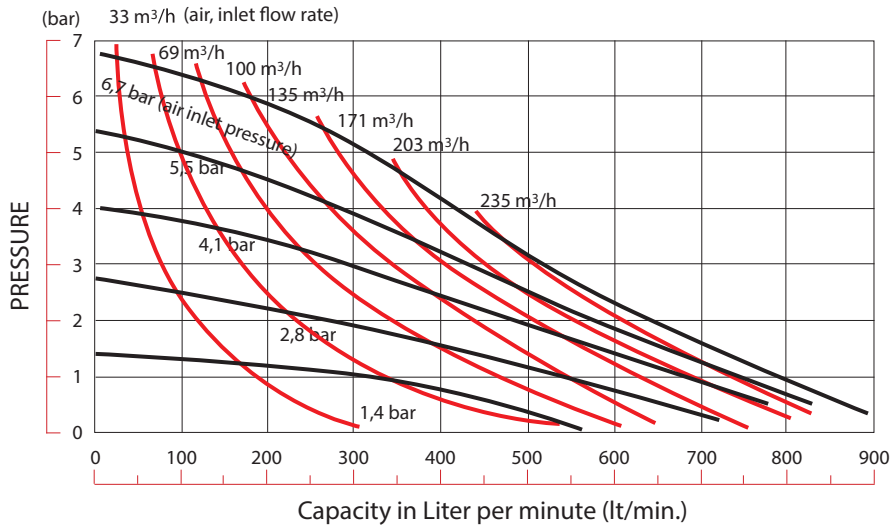

PUMP EXTERNAL DIMENSIONS

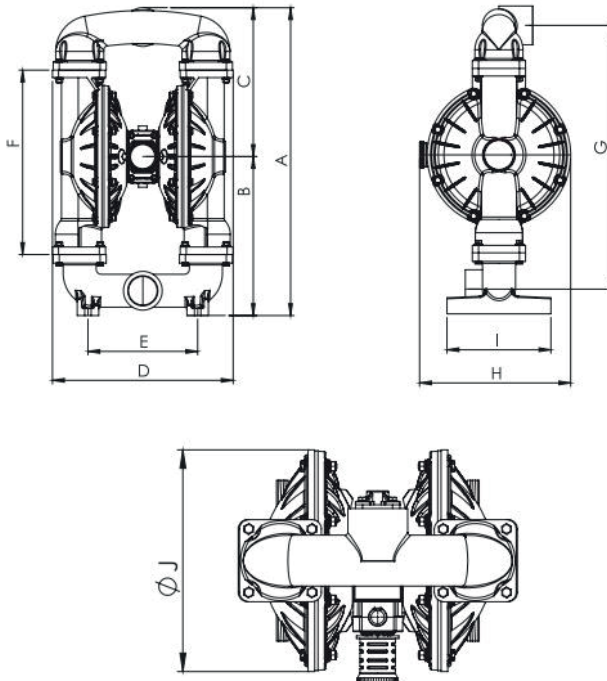

A	B	C	D	E	F	G	H	I	J
858	443	415	504	306	514	735	421	290	400



APPLICATION AREAS



- WASTE WATER TREATMENT
- MINING - ENERGY
- TEXTILE
- MARINE
- PACKAGING
- MACHINE-AUTOMATION
- AUTOMOTIVE
- FOOD INDUSTRY
- PAINT INDUSTRY

ADVANTAGES



- 1) Solid particles may pass through the pump.
- 2) Maintenance cost is low.
- 3) Liquid flow rate can also be adjusted when the air inlet pressure of the pump is adjusted.
- 4) The pump's air valve and pilot valve repair kits can be repaired without disassembling the pump.
- 5) It has the feature of working dry.
- 6) The suction depth of this pump is 6 m.

PUMP TECHNICAL SPECIFICATIONS

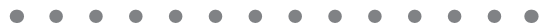

- Max. Capacity** : 55 l/min
- Fluid Inlet-Outlet** : 3/4"
- Max. Fluid Discharge** : 7 bar
- Body Material** : Aluminum
- Air Inlet Size** : 1/4"
- Solid Particle Size** : 3 mm
- Dry Suction Depth** : 6 m
- Max Air Pressure** : 7 bar
- Diaphragm Options** : Santoprene, Neoprene, Buna-N, EPDM, Teflon, Viton
- Ball Options** : Santoprene, Neoprene, Buna-N, EPDM, Teflon, Viton
- Ball Seat Options** : Santoprene, Neoprene, Buna-N, EPDM, Teflon, Viton

DIAPHRAGM PUMPS PERFORMANCE CURVES

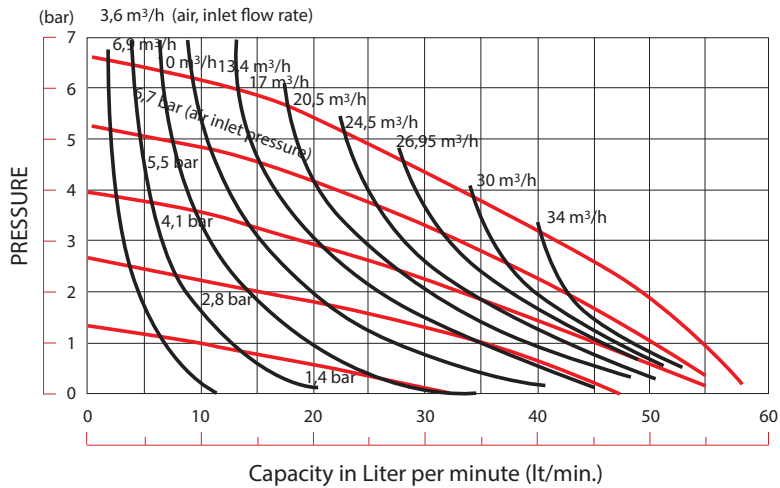

PUMP EXTERNAL DIMENSIONS

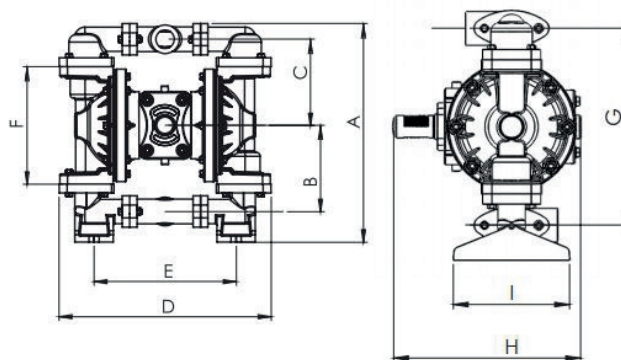

A	B	C	D	E	F	G	H	I	J
279	110	110	270	181	150	220	209	130	163



APPLICATION AREAS



- | | |
|-----------------------|--------------------|
| WASTE WATER TREATMENT | MARINE |
| TEXTILE | MACHINE-AUTOMATION |
| PACKAGING | DEFENSE INDUSTRY |
| AUTOMOTIVE | PETROL AND OIL |
| FOOD INDUSTRY | CERAMIC INDUSTRY |
| PAINT INDUSTRY | MEDICAL INDUSTRY |
| MINING - ENERGY | |

ADVANTAGES



- 1) Solid particles may pass through the pump.
- 2) Maintenance cost is low.
- 3) Liquid flow rate can also be adjusted when the air inlet pressure of the pump is adjusted.
- 4) The pump's air valve and pilot valve repair kits can be repaired without disassembling the pump.
- 5) It has the feature of working dry.
- 6) The suction depth of this pump is 6 m.

PUMP TECHNICAL SPECIFICATIONS

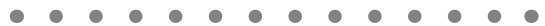

- | | |
|-----------------------------|---|
| Max. Capacity | : 150 l/min |
| Fluid Inlet-Outlet | : 1" |
| Max. Fluid Discharge | : 7 bar |
| Body Material | : Aluminum |
| Air Inlet Size | : ½" |
| Solid Particle Size | : 4 mm |
| Dry Suction Depth | : 6 m |
| Max Air Pressure | : 7 bar |
| Diaphragm Options | : Santoprene, Neoprene, Buna-N, EPDM, Teflon, Viton |
| Ball Options | : Santoprene, Neoprene, Buna-N, EPDM, Teflon, Viton |
| Ball Seat Options | : Santoprene, Neoprene, Buna-N, EPDM, Teflon, Viton |

DIAPHRAGM PUMPS PERFORMANCE CURVES

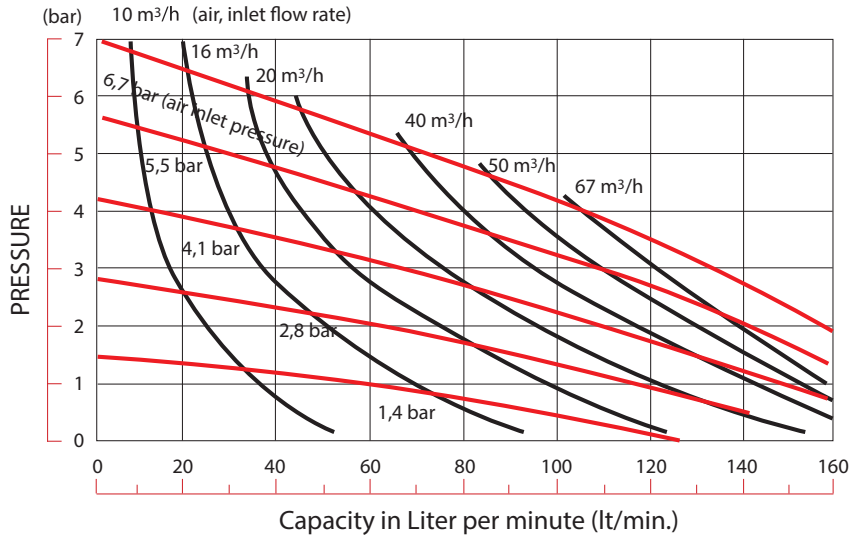

PUMP EXTERNAL DIMENSIONS

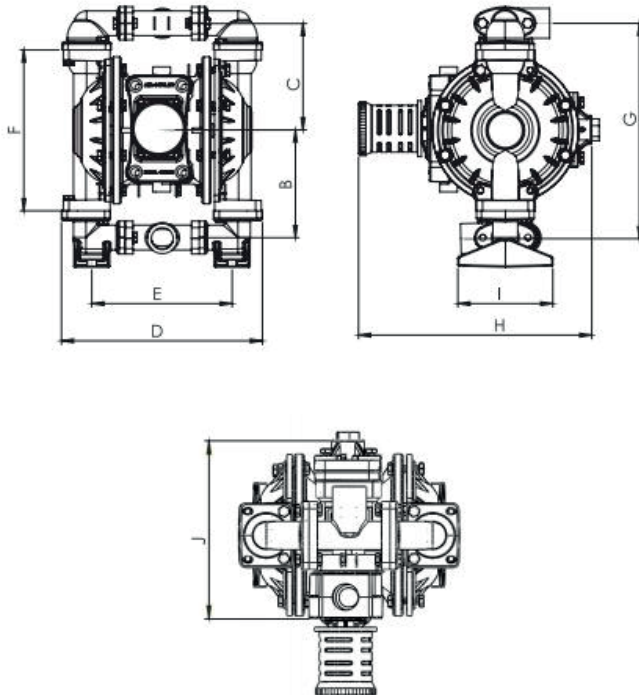

A	B	C	D	E	F	G	H	I	J
356	146	146	274	191	220	293	312	130	220



APPLICATION AREAS



- WASTE WATER TREATMENT
- MARINE
- TEXTILE
- MACHINE-AUTOMATION
- PACKAGING
- DEFENSE INDUSTRY
- AUTOMOTIVE
- PETROL AND OIL
- FOOD INDUSTRY
- CERAMIC INDUSTRY
- PAINT INDUSTRY
- MEDICAL INDUSTRY
- MINING - ENERGY

ADVANTAGES



- 1) Solid particles may pass through the pump.
- 2) Maintenance cost is low.
- 3) Liquid flow rate can also be adjusted when the air inlet pressure of the pump is adjusted.
- 4) The pump's air valve and pilot valve repair kits can be repaired without disassembling the pump.
- 5) It has the feature of working dry.
- 6) The suction depth of this pump is 6 m.

PUMP TECHNICAL SPECIFICATIONS

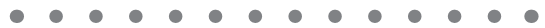

- Max. Capacity** : 400 l/min
- Fluid Inlet-Outlet** : 1½"
- Max. Fluid Discharge** : 7 bar
- Body Material** : Aluminum
- Air Inlet Size** : 3/4"
- Solid Particle Size** : 6 mm
- Dry Suction Depth** : 6 m
- Max Air Pressure** : 7 bar
- Diaphragm Options** : Santoprene, Neoprene, Buna-N, EPDM, Teflon, Viton
- Ball Options** : Santoprene, Neoprene, Buna-N, EPDM, Teflon, Viton
- Ball Seat Options** : Santoprene, Neoprene, Buna-N, EPDM, Teflon, Viton

DIAPHRAGM PUMPS PERFORMANCE CURVES

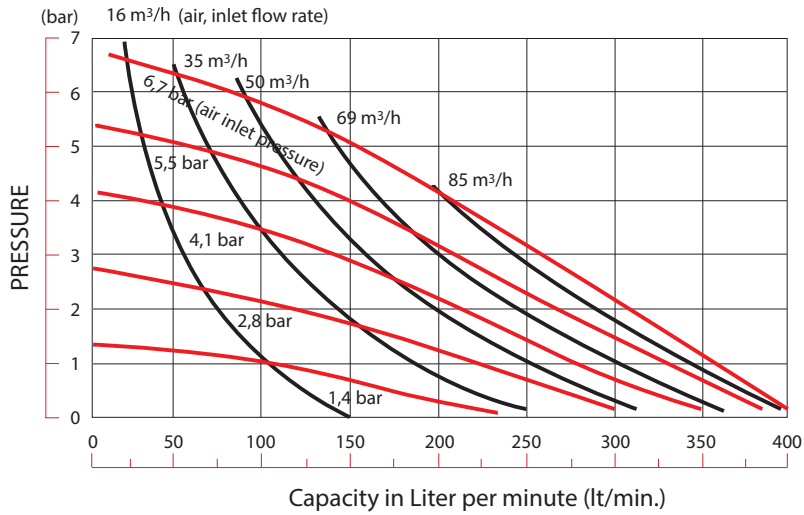

PUMP EXTERNAL DIMENSIONS

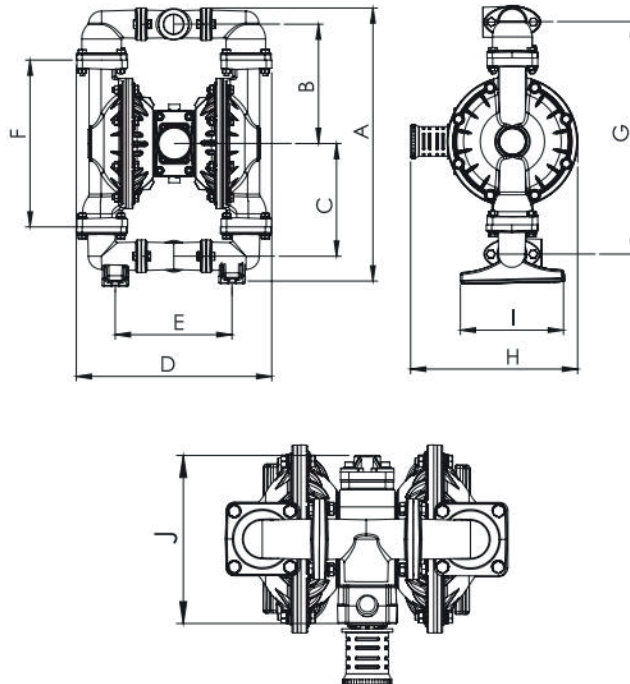

A	B	C	D	E	F	G	H	I	J
605	260	245	425	253	363	505	363	224	253



APPLICATION AREAS

- WASTE WATER TREATMENT
- TEXTILE
- PACKAGING
- AUTOMOTIVE
- FOOD INDUSTRY
- PAINT INDUSTRY
- MINING - ENERGY
- MARINE
- MACHINE-AUTOMATION
- DEFENSE INDUSTRY
- PETROL AND OIL
- CERAMIC INDUSTRY
- MEDICAL INDUSTRY

ADVANTAGES

- 1) Solid particles may pass through the pump.
- 2) Maintenance cost is low.
- 3) Liquid flow rate can also be adjusted when the air inlet pressure of the pump is adjusted.
- 4) The pump's air valve and pilot valve repair kits can be repaired without disassembling the pump.
- 5) It has the feature of working dry.
- 6) The suction depth of this pump is 6 m.

PUMP TECHNICAL SPECIFICATIONS

- Max. Capacity** : 560 l/min
- Fluid Inlet-Outlet** : 2"
- Max. Fluid Discharge** : 7 bar
- Body Material** : Aluminum
- Air Inlet Size** : 3/4"
- Solid Particle Size** : 6 mm
- Dry Suction Depth** : 6 m
- Max Air Pressure** : 7 bar
- Diaphragm Options** : Santoprene, Neoprene, Buna-N, EPDM, Teflon, Viton
- Ball Options** : Santoprene, Neoprene, Buna-N, EPDM, Teflon, Viton
- Ball Seat Options** : Santoprene, Neoprene, Buna-N, EPDM, Teflon, Viton

DIAPHRAGM PUMPS PERFORMANCE CURVES

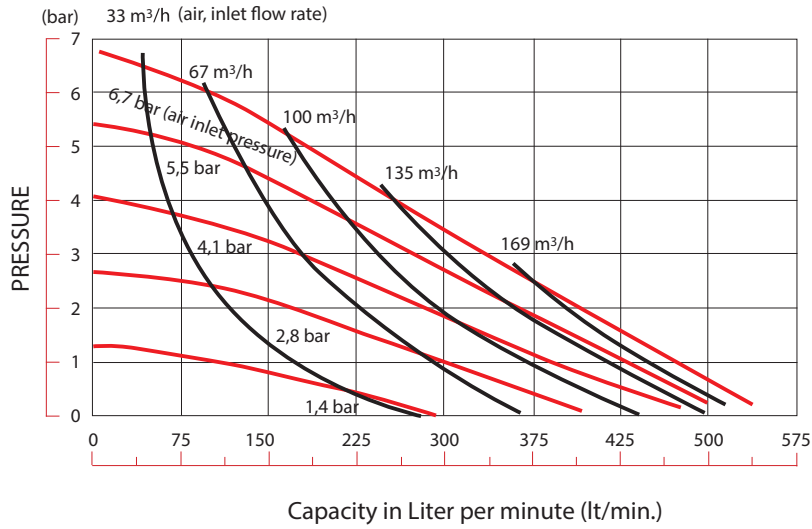

PUMP EXTERNAL DIMENSIONS

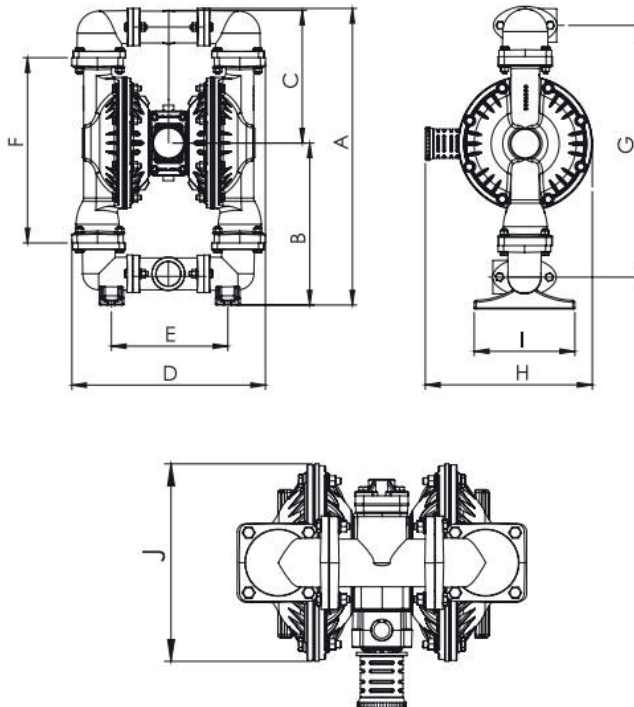

A	B	C	D	E	F	G	H	I	J
669	365	299	438	263	418	556	370	223	298

HP30 AL METALLIC BODY PUMP

HUGEPUMP



APPLICATION AREAS



- | | |
|---|--|
|  WASTE WATER TREATMENT |  MARINE |
|  TEXTILE |  MACHINE-AUTOMATION |
|  PACKAGING |  DEFENSE INDUSTRY |
|  AUTOMOTIVE |  PETROL AND OIL |
|  FOOD INDUSTRY |  CERAMIC INDUSTRY |
|  PAINT INDUSTRY |  MEDICAL INDUSTRY |
|  MINING - ENERGY | |

ADVANTAGES



- 1) Solid particles may pass through the pump.
- 2) Maintenance cost is low.
- 3) Liquid flow rate can also be adjusted when the air inlet pressure of the pump is adjusted.
- 4) The pump's air valve and pilot valve repair kits can be repaired without disassembling the pump.
- 5) It has the feature of working dry.
- 6) The suction depth of this pump is 6 m.

PUMP TECHNICAL SPECIFICATIONS

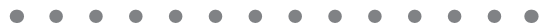

- | | |
|-----------------------------|---|
| Max. Capacity | : 890 l/min |
| Fluid Inlet-Outlet | : 3" |
| Max. Fluid Discharge | : 7 bar |
| Body Material | : Aluminum, Cast Iron, Stainless Steel |
| Air Inlet Size | : 3/4" |
| Solid Particle Size | : 8 mm |
| Dry Suction Depth | : 6 m |
| Max Air Pressure | : 7 bar |
| Diaphragm Options | : Santoprene, Neoprene, Buna-N, EPDM, Teflon, Viton |
| Ball Options | : Santoprene, Neoprene, Buna-N, EPDM, Teflon, Viton |
| Ball Seat Options | : Santoprene, Neoprene, Buna-N, EPDM, Teflon, Viton |

DIAPHRAGM PUMPS PERFORMANCE CURVES

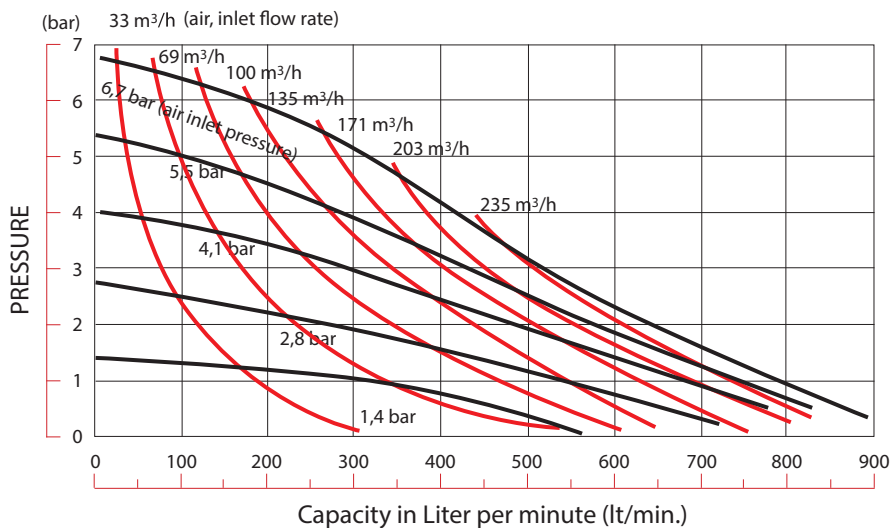

PUMP EXTERNAL DIMENSIONS

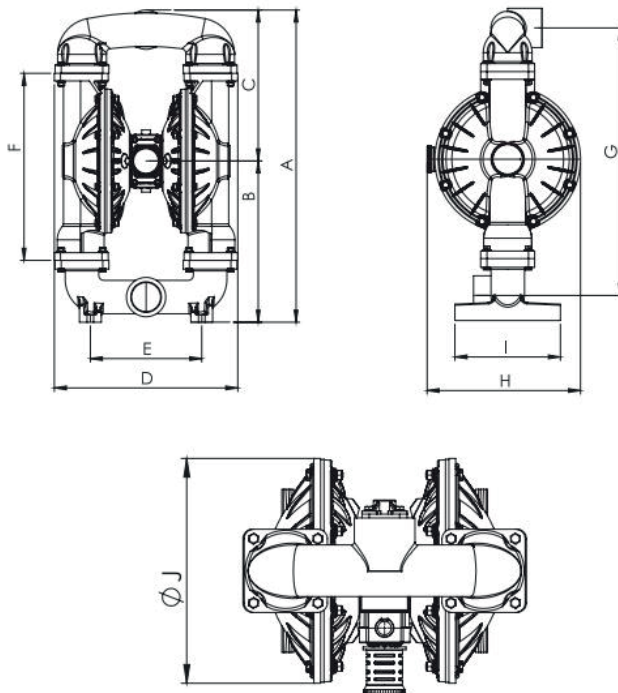

A	B	C	D	E	F	G	H	I	J
858	443	415	504	306	514	735	421	290	400

HP05 METALLIC BODY PUMP (SIDED INLET/OUTLET)



APPLICATION AREAS

- WASTE WATER TREATMENT
- TEXTILE
- PACKAGING
- AUTOMOTIVE
- FOOD INDUSTRY
- PAINT INDUSTRY
- MINING - ENERGY
- MARINE
- MACHINE-AUTOMATION

ADVANTAGES

- 1) Solid particles may pass through the pump.
- 2) Maintenance cost is low.
- 3) Liquid flow rate can also be adjusted when the air inlet pressure of the pump is adjusted.
- 4) The pump's air valve and pilot valve repair kits can be repaired without disassembling the pump.
- 5) It has the feature of working dry.
- 6) The suction depth of this pump is 6 m.

PUMP TECHNICAL SPECIFICATIONS

- Max. Capacity** : 55 l/min
- Fluid Inlet-Outlet** : 3/4"
- Max. Fluid Discharge** : 7 bar
- Body Material** : Aluminum
- Air Inlet Size** : 1/4"
- Solid Particle Size** : 3 mm
- Dry Suction Depth** : 6 m
- Max Air Pressure** : 7 bar
- Diaphragm Options** : Santoprene, Neoprene, Buna-N, EPDM, Teflon, Viton
- Ball Options** : Santoprene, Neoprene, Buna-N, EPDM, Teflon, Viton
- Ball Seat Options** : Santoprene, Neoprene, Buna-N, EPDM, Teflon, Viton

DIAPHRAGM PUMPS PERFORMANCE CURVES

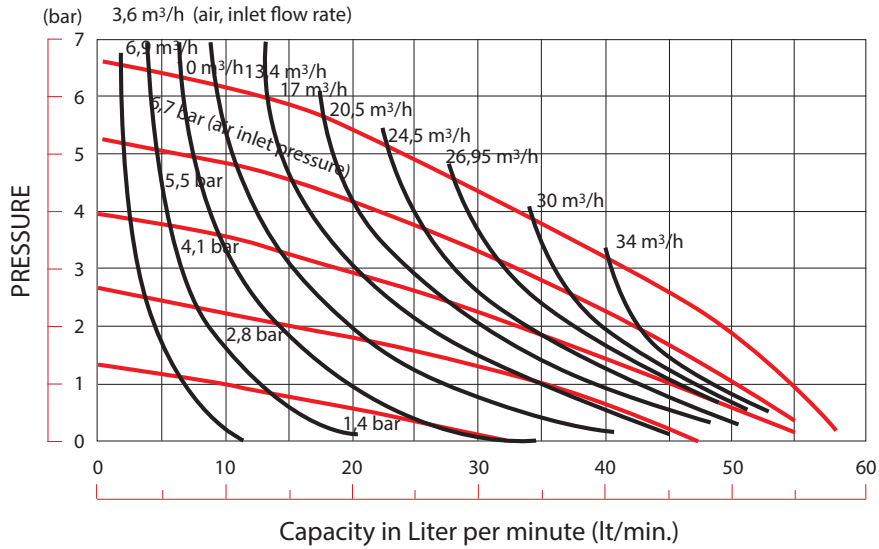

PUMP EXTERNAL DIMENSIONS

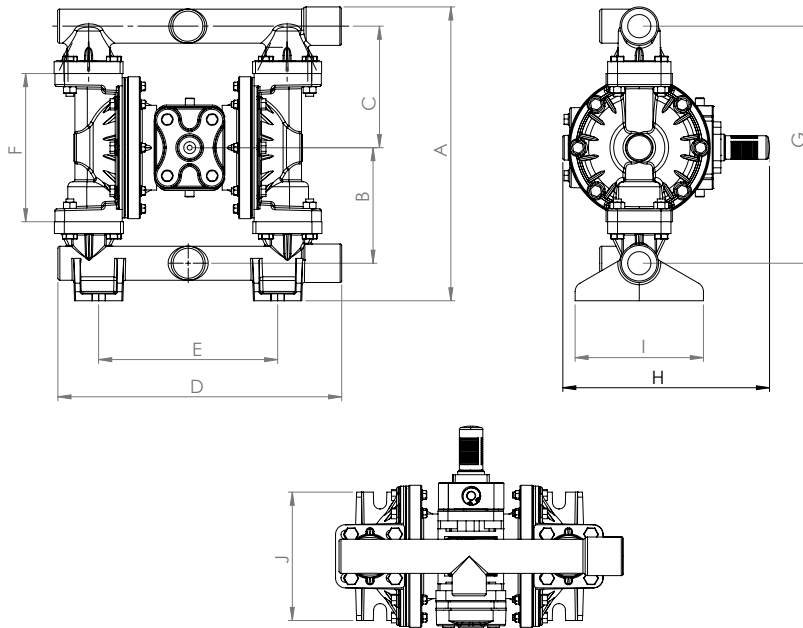

A	B	C	D	E	F	G	H	I	J
298	117	113	287	181	150	240	209	130	130

HP10 METALLIC BODY PUMP (SIDED INLET/OUTLET)



APPLICATION AREAS



- WASTE WATER TREATMENT
- TEXTILE
- PACKAGING
- AUTOMOTIVE
- FOOD INDUSTRY
- PAINT INDUSTRY
- MINING - ENERGY
- MARINE
- MACHINE-AUTOMATION
- DEFENSE INDUSTRY
- PETROL AND OIL
- CERAMIC INDUSTRY
- MEDICAL INDUSTRY

ADVANTAGES



- 1) Solid particles may pass through the pump.
- 2) Maintenance cost is low.
- 3) Liquid flow rate can also be adjusted when the air inlet pressure of the pump is adjusted.
- 4) The pump's air valve and pilot valve repair kits can be repaired without disassembling the pump.
- 5) It has the feature of working dry.
- 6) The suction depth of this pump is 6 m.

PUMP TECHNICAL SPECIFICATIONS

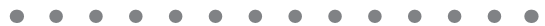

- Max. Capacity** : 150 l/min
- Fluid Inlet-Outlet** : 1"
- Max. Fluid Discharge** : 7 bar
- Body Material** : Aluminum
- Air Inlet Size** : ½"
- Solid Particle Size** : 4 mm
- Dry Suction Depth** : 6 m
- Max Air Pressure** : 7 bar
- Diaphragm Options** : Santoprene, Neoprene, Buna-N, EPDM, Teflon, Viton
- Ball Options** : Santoprene, Neoprene, Buna-N, EPDM, Teflon, Viton
- Ball Seat Options** : Santoprene, Neoprene, Buna-N, EPDM, Teflon, Viton

DIAPHRAGM PUMPS PERFORMANCE CURVES

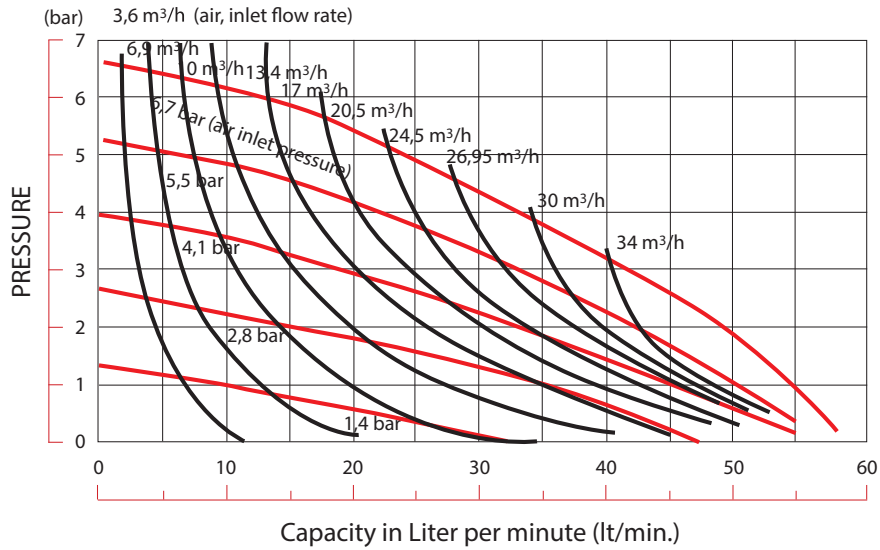

PUMP EXTERNAL DIMENSIONS

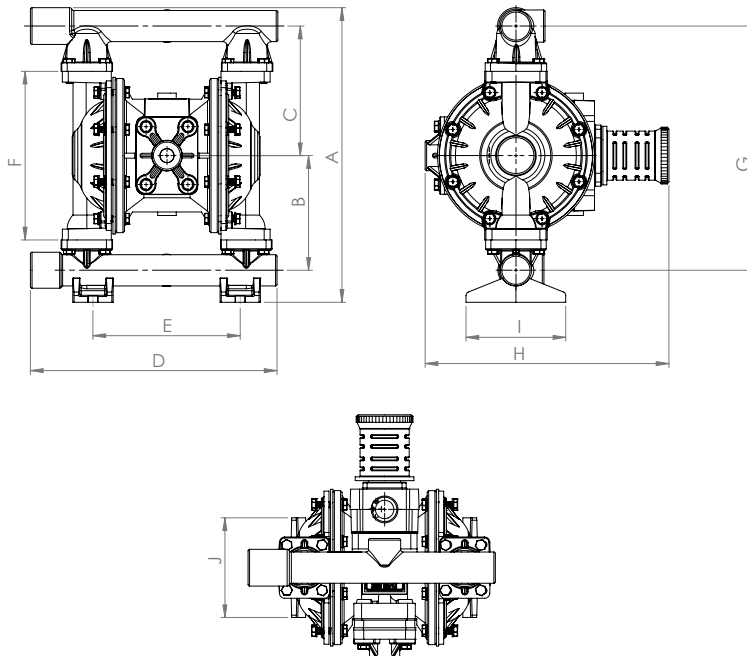

A	B	C	D	E	F	G	H	I	J
384	150	169	321	192	220	318	318	130	130



APPLICATION AREAS



- WASTE WATER TREATMENT
- TEXTILE
- PACKAGING
- AUTOMOTIVE
- FOOD INDUSTRY
- PAINT INDUSTRY
- MINING - ENERGY
- MARINE
- MACHINE-AUTOMATION
- DEFENSE INDUSTRY
- PETROL AND OIL
- CERAMIC INDUSTRY
- MEDICAL INDUSTRY

ADVANTAGES

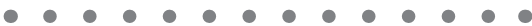

- 1) Solid particles may pass through the pump.
- 2) Maintenance cost is low.
- 3) Liquid flow rate can also be adjusted when the air inlet pressure of the pump is adjusted.
- 4) The pump's air valve and pilot valve repair kits can be repaired without disassembling the pump.
- 5) It has the feature of working dry.
- 6) The suction depth of this pump is 6 m.

PUMP TECHNICAL SPECIFICATIONS

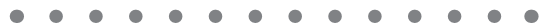

- Max. Capacity** : 150 l/min
- Fluid Inlet-Outlet** : 1"
- Max. Fluid Discharge** : 7 bar
- Body Material** : Cast Iron
- Air Inlet Size** : ½"
- Solid Particle Size** : 4 mm
- Dry Suction Depth** : 6 m
- Max Air Pressure** : 7 bar
- Diaphragm Options** : Santoprene, Neoprene, Buna-N, EPDM, Teflon, Viton
- Ball Options** : Santoprene, Neoprene, Buna-N, EPDM, Teflon, Viton
- Ball Seat Options** : Santoprene, Neoprene, Buna-N, EPDM, Teflon, Viton

DIAPHRAGM PUMPS PERFORMANCE CURVES

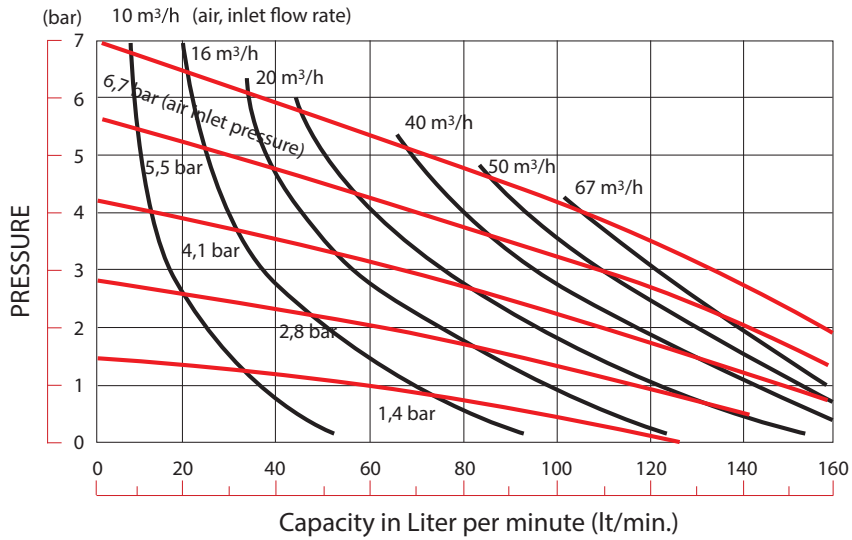

PUMP EXTERNAL DIMENSIONS

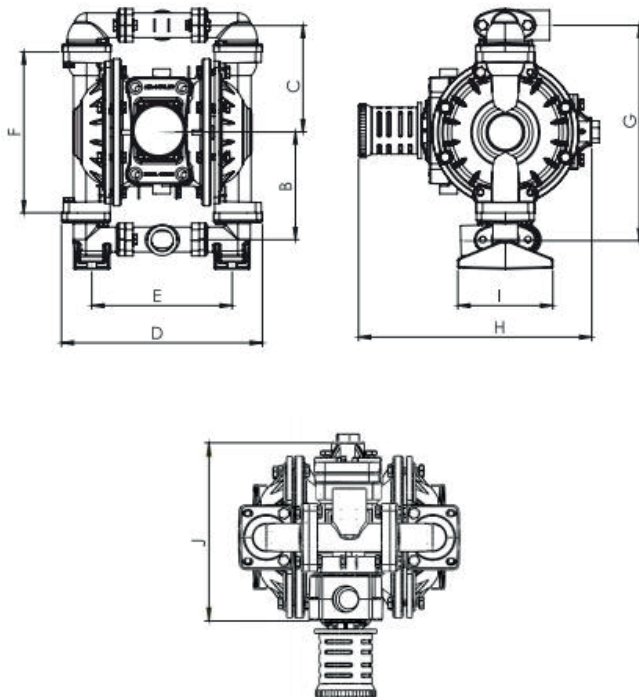

A	B	C	D	E	F	G	H	I	J
356	146	146	274	191	220	293	312	130	220



APPLICATION AREAS



- WASTE WATER TREATMENT
- MARINE
- TEXTILE
- MACHINE-AUTOMATION
- PACKAGING
- DEFENSE INDUSTRY
- AUTOMOTIVE
- PETROL AND OIL
- FOOD INDUSTRY
- CERAMIC INDUSTRY
- PAINT INDUSTRY
- MEDICAL INDUSTRY
- MINING - ENERGY

ADVANTAGES



- 1) Solid particles may pass through the pump.
- 2) Maintenance cost is low.
- 3) Liquid flow rate can also be adjusted when the air inlet pressure of the pump is adjusted.
- 4) The pump's air valve and pilot valve repair kits can be repaired without disassembling the pump.
- 5) It has the feature of working dry.
- 6) The suction depth of this pump is 6 m.

PUMP TECHNICAL SPECIFICATIONS

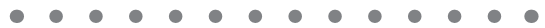

- Max. Capacity** : 400 l/min
- Fluid Inlet-Outlet** : 1½"
- Max. Fluid Discharge** : 7 bar
- Body Material** : Cast Iron
- Air Inlet Size** : 3/4"
- Solid Particle Size** : 6 mm
- Dry Suction Depth** : 6 m
- Max Air Pressure** : 7 bar
- Diaphragm Options** : Santoprene, Neoprene, Buna-N, EPDM, Teflon, Viton
- Ball Options** : Santoprene, Neoprene, Buna-N, EPDM, Teflon, Viton
- Ball Seat Options** : Santoprene, Neoprene, Buna-N, EPDM, Teflon, Viton

DIAPHRAGM PUMPS PERFORMANCE CURVES

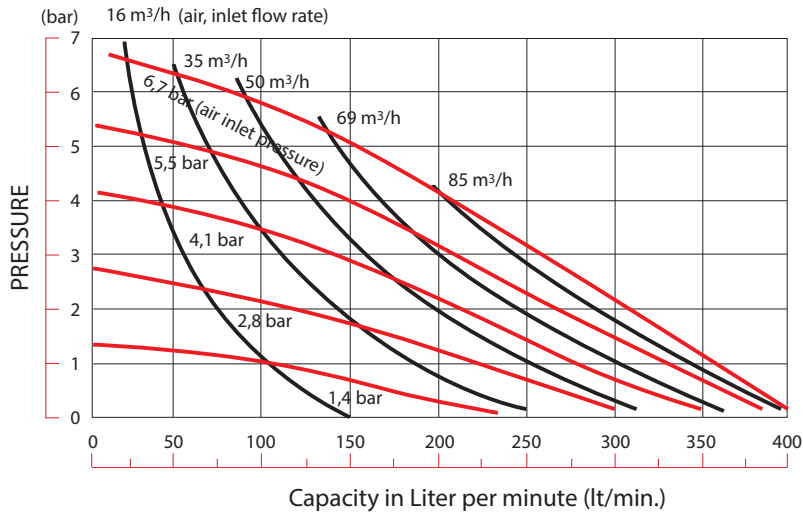

PUMP EXTERNAL DIMENSIONS

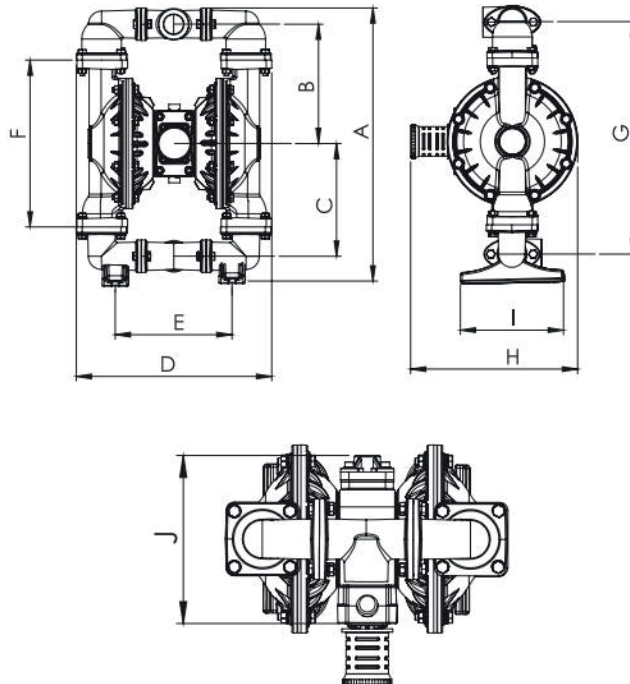

A	B	C	D	E	F	G	H	I	J
605	260	245	425	253	363	505	363	224	253



APPLICATION AREAS



- WASTE WATER TREATMENT
- MARINE
- TEXTILE
- MACHINE-AUTOMATION
- PACKAGING
- DEFENSE INDUSTRY
- AUTOMOTIVE
- PETROL AND OIL
- FOOD INDUSTRY
- CERAMIC INDUSTRY
- PAINT INDUSTRY
- MEDICAL INDUSTRY
- MINING - ENERGY

ADVANTAGES



- 1) Solid particles may pass through the pump.
- 2) Maintenance cost is low.
- 3) Liquid flow rate can also be adjusted when the air inlet pressure of the pump is adjusted.
- 4) The pump's air valve and pilot valve repair kits can be repaired without disassembling the pump.
- 5) It has the feature of working dry.
- 6) The suction depth of this pump is 6 m.

PUMP TECHNICAL SPECIFICATIONS

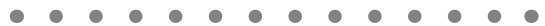

- Max. Capacity** : 560 l/min
- Fluid Inlet-Outlet** : 2"
- Max. Fluid Discharge** : 7 bar
- Body Material** : Cast Iron
- Air Inlet Size** : 3/4"
- Solid Particle Size** : 6 mm
- Dry Suction Depth** : 6 m
- Max Air Pressure** : 7 bar
- Diaphragm Options** : Santoprene, Neoprene, Buna-N, EPDM, Teflon, Viton
- Ball Options** : Santoprene, Neoprene, Buna-N, EPDM, Teflon, Viton
- Ball Seat Options** : Santoprene, Neoprene, Buna-N, EPDM, Teflon, Viton

DIAPHRAGM PUMPS PERFORMANCE CURVES

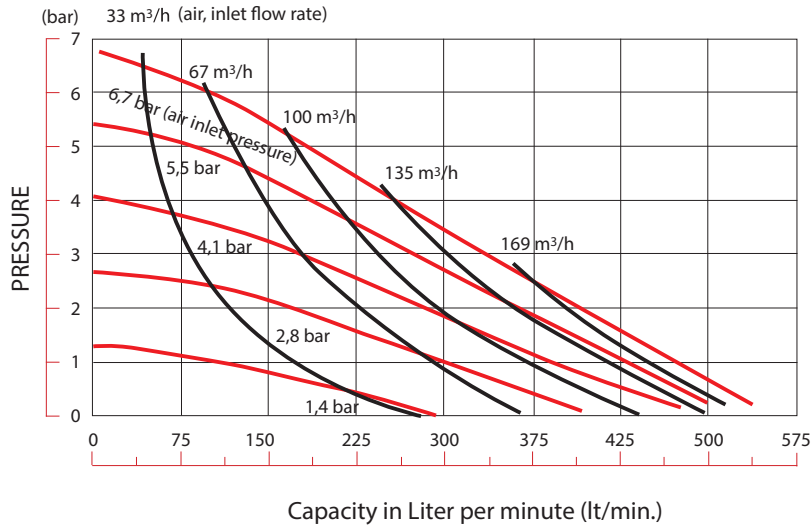

PUMP EXTERNAL DIMENSIONS

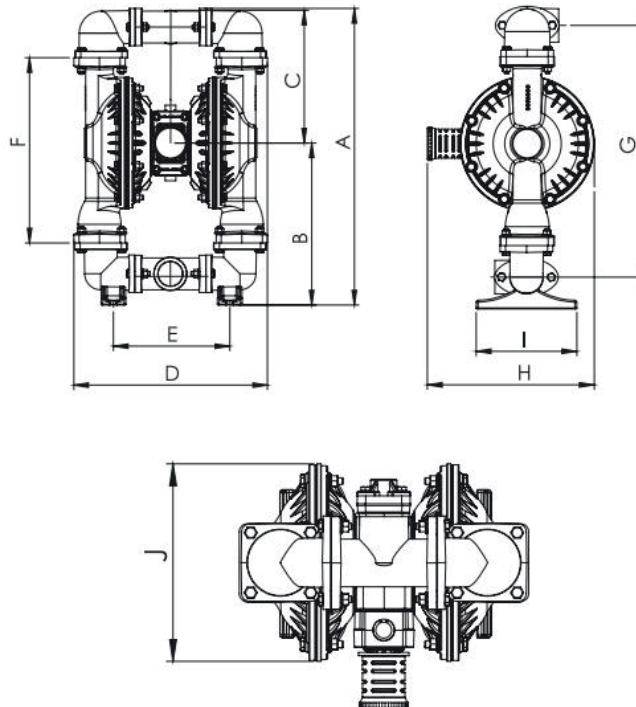

A	B	C	D	E	F	G	H	I	J
669	365	299	438	263	418	556	370	223	298



APPLICATION AREAS



- | | |
|-----------------------|--------------------|
| WASTE WATER TREATMENT | MARINE |
| TEXTILE | MACHINE-AUTOMATION |
| PACKAGING | DEFENSE INDUSTRY |
| AUTOMOTIVE | PETROL AND OIL |
| FOOD INDUSTRY | CERAMIC INDUSTRY |
| PAINT INDUSTRY | MEDICAL INDUSTRY |
| MINING - ENERGY | |

ADVANTAGES



- 1) Solid particles may pass through the pump.
- 2) Maintenance cost is low.
- 3) Liquid flow rate can also be adjusted when the air inlet pressure of the pump is adjusted.
- 4) The pump's air valve and pilot valve repair kits can be repaired without disassembling the pump.
- 5) It has the feature of working dry.
- 6) The suction depth of this pump is 6 m.

PUMP TECHNICAL SPECIFICATIONS

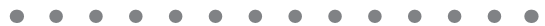

- | | |
|-----------------------------|---|
| Max. Capacity | : 890 l/min |
| Fluid Inlet-Outlet | : 3" |
| Max. Fluid Discharge | : 7 bar |
| Body Material | : Cast Iron |
| Air Inlet Size | : 3/4" |
| Solid Particle Size | : 8 mm |
| Dry Suction Depth | : 6 m |
| Max Air Pressure | : 7 bar |
| Diaphragm Options | : Santoprene, Neoprene, Buna-N, EPDM, Teflon, Viton |
| Ball Options | : Santoprene, Neoprene, Buna-N, EPDM, Teflon, Viton |
| Ball Seat Options | : Santoprene, Neoprene, Buna-N, EPDM, Teflon, Viton |

DIAPHRAGM PUMPS PERFORMANCE CURVES

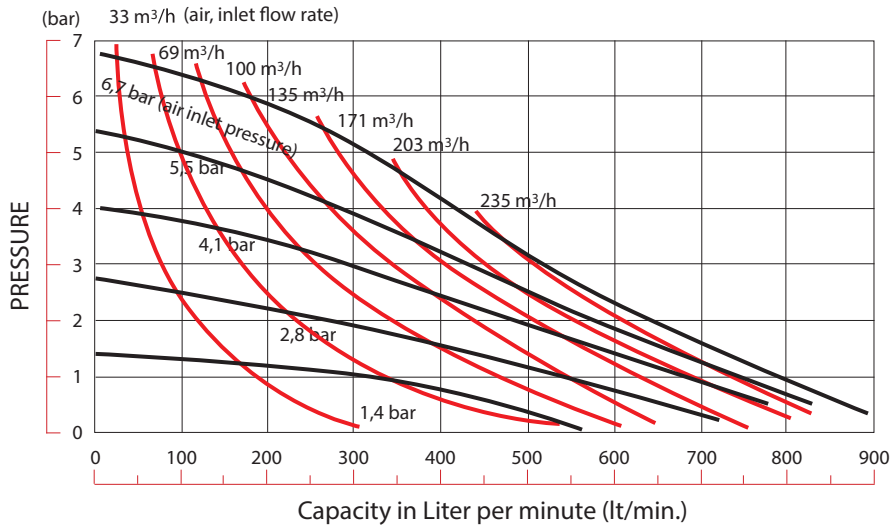

PUMP EXTERNAL DIMENSIONS

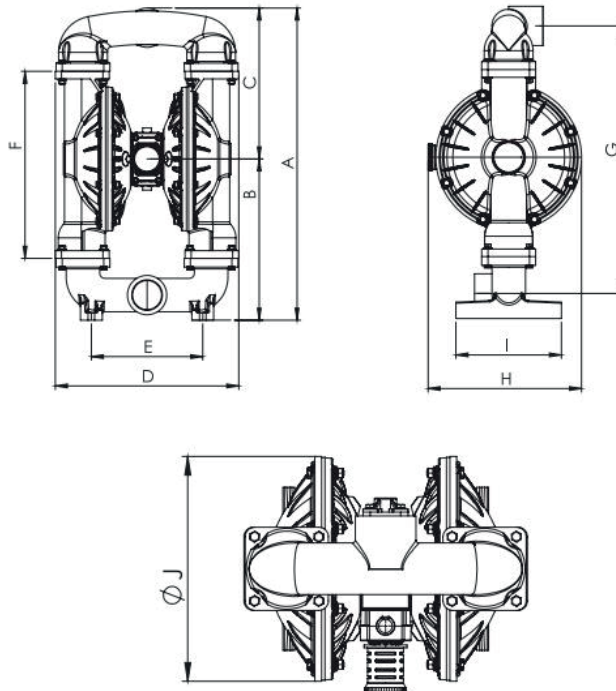

A	B	C	D	E	F	G	H	I	J
858	443	415	504	306	514	735	421	290	400



APPLICATION AREAS



- WASTE WATER TREATMENT
- MARINE
- TEXTILE
- MACHINE-AUTOMATION
- PACKAGING
- DEFENSE INDUSTRY
- AUTOMOTIVE
- PETROL AND OIL
- FOOD INDUSTRY
- CERAMIC INDUSTRY
- PAINT INDUSTRY
- MEDICAL INDUSTRY
- MINING - ENERGY

ADVANTAGES



- 1) Solid particles may pass through the pump.
- 2) Maintenance cost is low.
- 3) Liquid flow rate can also be adjusted when the air inlet pressure of the pump is adjusted.
- 4) The pump's air valve and pilot valve repair kits can be repaired without disassembling the pump.
- 5) It has the feature of working dry.
- 6) The suction depth of this pump is 6 m.

PUMP TECHNICAL SPECIFICATIONS

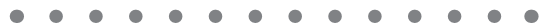

- Max. Capacity** : 150 l/min
- Fluid Inlet-Outlet** : 1"
- Max. Fluid Discharge** : 7 bar
- Body Material** : Stainless Steel
- Air Inlet Size** : ½"
- Solid Particle Size** : 4 mm
- Dry Suction Depth** : 6 m
- Max Air Pressure** : 7 bar
- Diaphragm Options** : Santoprene, Neoprene, Buna-N, EPDM, Teflon, Viton
- Ball Options** : Santoprene, Neoprene, Buna-N, EPDM, Teflon, Viton
- Ball Seat Options** : Santoprene, Neoprene, Buna-N, EPDM, Teflon, Viton

DIAPHRAGM PUMPS PERFORMANCE CURVES

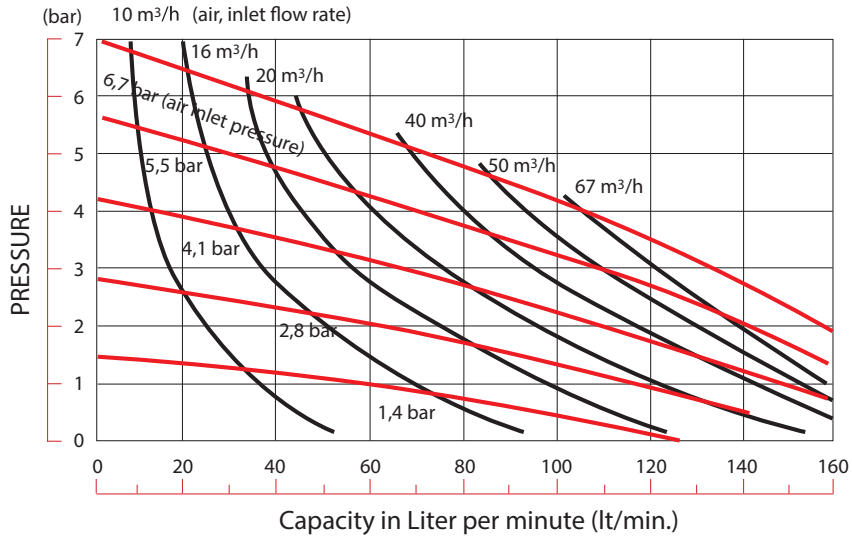

PUMP EXTERNAL DIMENSIONS

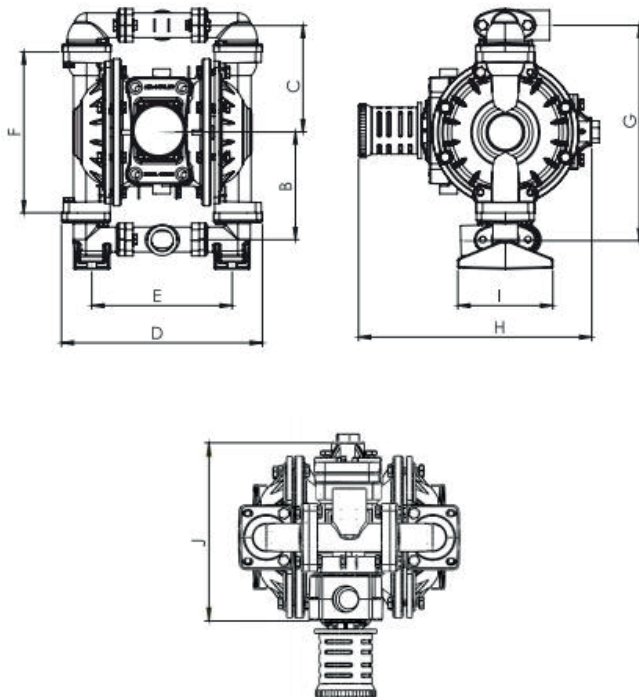

A	B	C	D	E	F	G	H	I	J
356	146	146	274	191	220	293	312	130	220



APPLICATION AREAS

- WASTE WATER TREATMENT
- TEXTILE
- PACKAGING
- AUTOMOTIVE
- FOOD INDUSTRY
- PAINT INDUSTRY
- MINING - ENERGY
- MARINE
- MACHINE-AUTOMATION
- DEFENSE INDUSTRY
- PETROL AND OIL
- CERAMIC INDUSTRY
- MEDICAL INDUSTRY

ADVANTAGES

- 1) Solid particles may pass through the pump.
- 2) Maintenance cost is low.
- 3) Liquid flow rate can also be adjusted when the air inlet pressure of the pump is adjusted.
- 4) The pump's air valve and pilot valve repair kits can be repaired without disassembling the pump.
- 5) It has the feature of working dry.
- 6) The suction depth of this pump is 6 m.

PUMP TECHNICAL SPECIFICATIONS

- Max. Capacity** : 400 l/min
- Fluid Inlet-Outlet** : 1½"
- Max. Fluid Discharge** : 7 bar
- Body Material** : Stainless Steel
- Air Inlet Size** : 3/4"
- Solid Particle Size** : 6 mm
- Dry Suction Depth** : 6 m
- Max Air Pressure** : 7 bar
- Diaphragm Options** : Santoprene, Neoprene, Buna-N, EPDM, Teflon, Viton
- Ball Options** : Santoprene, Neoprene, Buna-N, EPDM, Teflon, Viton
- Ball Seat Options** : Santoprene, Neoprene, Buna-N, EPDM, Teflon, Viton

DIAPHRAGM PUMPS PERFORMANCE CURVES

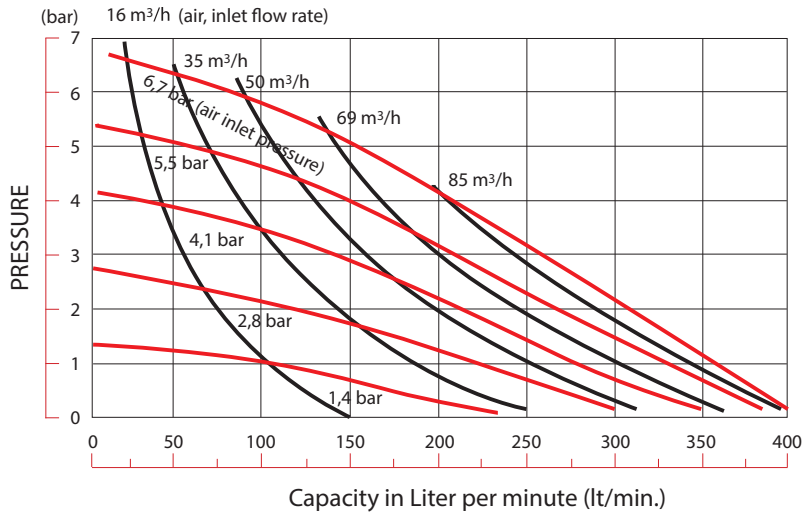

PUMP EXTERNAL DIMENSIONS

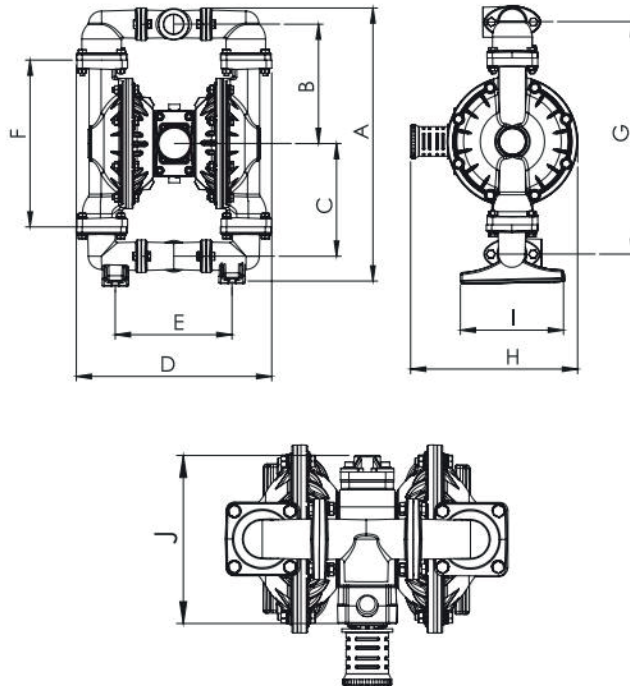

A	B	C	D	E	F	G	H	I	J
605	260	245	425	253	363	505	363	224	253



APPLICATION AREAS

- WASTE WATER TREATMENT
- TEXTILE
- PACKAGING
- AUTOMOTIVE
- FOOD INDUSTRY
- PAINT INDUSTRY
- MINING - ENERGY
- MARINE
- MACHINE-AUTOMATION
- DEFENSE INDUSTRY
- PETROL AND OIL
- CERAMIC INDUSTRY
- MEDICAL INDUSTRY

ADVANTAGES

- 1) Solid particles may pass through the pump.
- 2) Maintenance cost is low.
- 3) Liquid flow rate can also be adjusted when the air inlet pressure of the pump is adjusted.
- 4) The pump's air valve and pilot valve repair kits can be repaired without disassembling the pump.
- 5) It has the feature of working dry.
- 6) The suction depth of this pump is 6 m.

PUMP TECHNICAL SPECIFICATIONS

- Max. Capacity** : 560 l/min
- Fluid Inlet-Outlet** : 2"
- Max. Fluid Discharge** : 7 bar
- Body Material** : Stainless Steel
- Air Inlet Size** : 3/4"
- Solid Particle Size** : 6 mm
- Dry Suction Depth** : 6 m
- Max Air Pressure** : 7 bar
- Diaphragm Options** : Santoprene, Neoprene, Buna-N, EPDM, Teflon, Viton
- Ball Options** : Santoprene, Neoprene, Buna-N, EPDM, Teflon, Viton
- Ball Seat Options** : Santoprene, Neoprene, Buna-N, EPDM, Teflon, Viton

DIAPHRAGM PUMPS PERFORMANCE CURVES

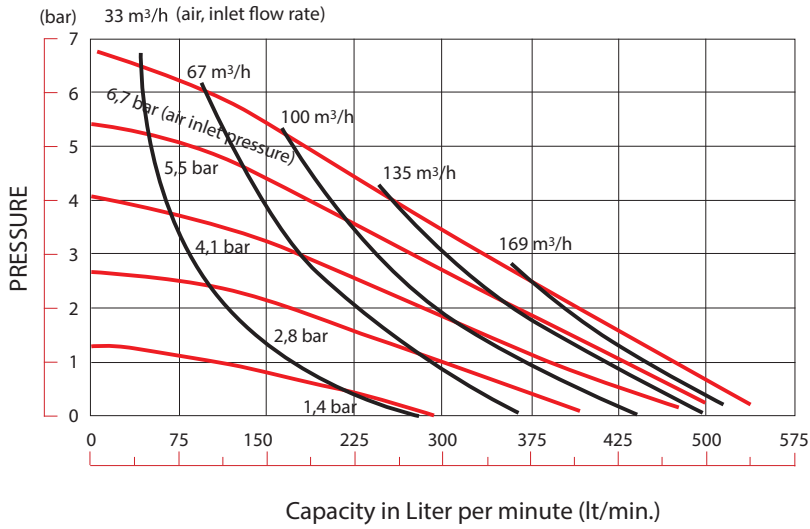

PUMP EXTERNAL DIMENSIONS

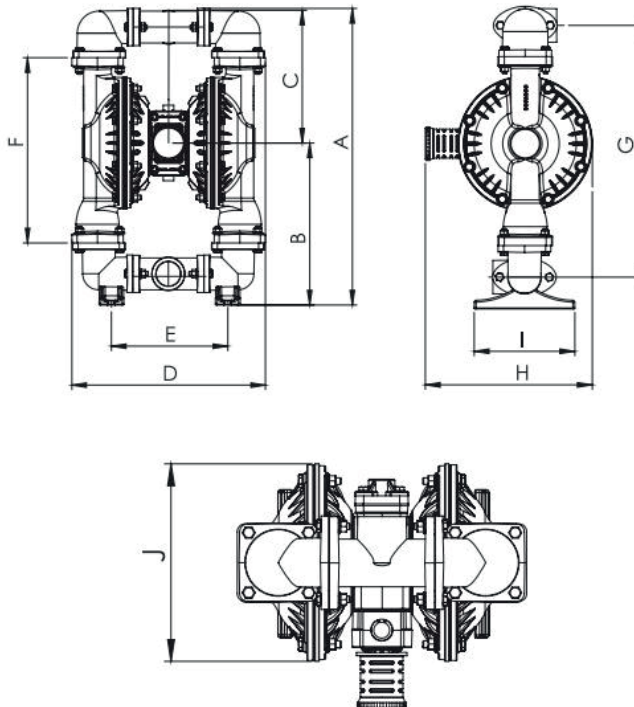

A	B	C	D	E	F	G	H	I	J
669	365	299	438	263	418	556	370	223	298



APPLICATION AREAS



- WASTE WATER TREATMENT
- MARINE
- TEXTILE
- MACHINE-AUTOMATION
- PACKAGING
- DEFENSE INDUSTRY
- AUTOMOTIVE
- PETROL AND OIL
- FOOD INDUSTRY
- CERAMIC INDUSTRY
- PAINT INDUSTRY
- MEDICAL INDUSTRY
- MINING - ENERGY

ADVANTAGES



- 1) Solid particles may pass through the pump.
- 2) Maintenance cost is low.
- 3) Liquid flow rate can also be adjusted when the air inlet pressure of the pump is adjusted.
- 4) The pump's air valve and pilot valve repair kits can be repaired without disassembling the pump.
- 5) It has the feature of working dry.
- 6) The suction depth of this pump is 6 m.

PUMP TECHNICAL SPECIFICATIONS



- Max. Capacity** : 890 l/min
- Fluid Inlet-Outlet** : 3"
- Max. Fluid Discharge** : 7 bar
- Body Material** : Stainless Steel
- Air Inlet Size** : 3/4"
- Solid Particle Size** : 8 mm
- Dry Suction Depth** : 6 m
- Max Air Pressure** : 7 bar
- Diaphragm Options** : Santoprene, Neoprene, Buna-N, EPDM, Teflon, Viton
- Ball Options** : Santoprene, Neoprene, Buna-N, EPDM, Teflon, Viton
- Ball Seat Options** : Santoprene, Neoprene, Buna-N, EPDM, Teflon, Viton

DIAPHRAGM PUMPS PERFORMANCE CURVES

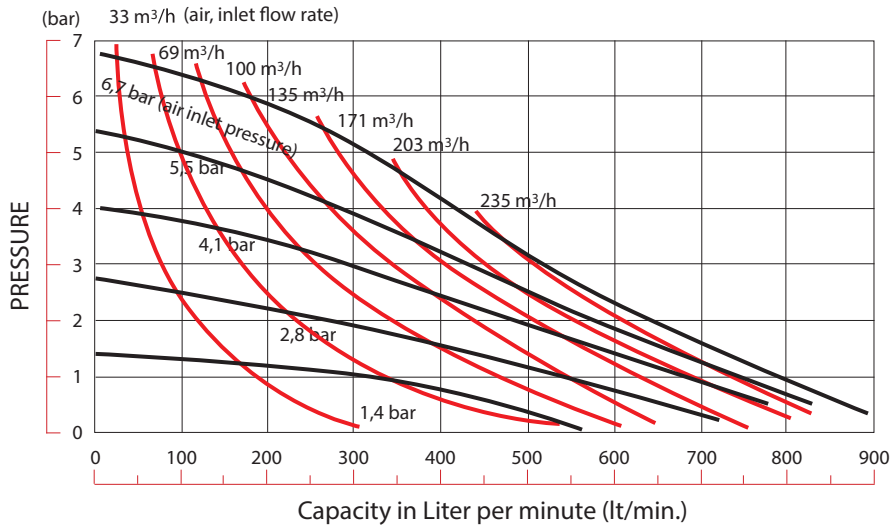

PUMP EXTERNAL DIMENSIONS

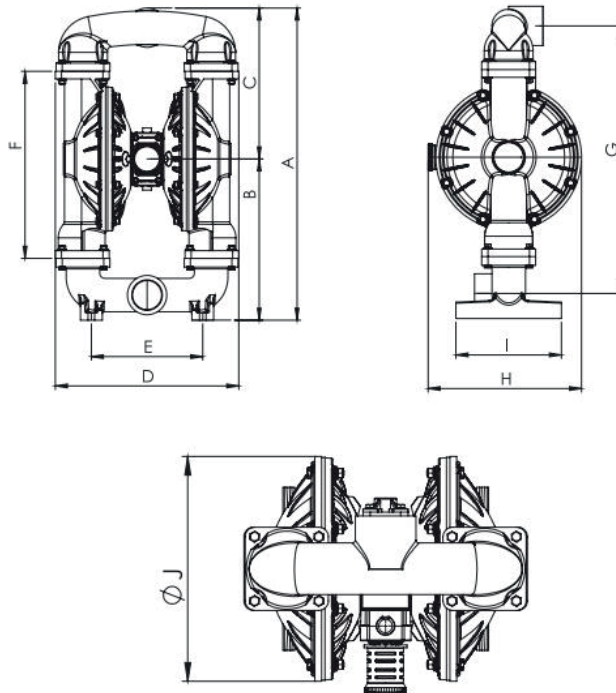

A	B	C	D	E	F	G	H	I	J
858	443	415	504	306	514	735	421	290	400

APPLICATION AREAS

- WASTE WATER TREATMENT
- TEXTILE
- PACKAGING
- AUTOMOTIVE
- FOOD INDUSTRY
- PAINT INDUSTRY
- MINING - ENERGY
- MARINE
- MACHINE-AUTOMATION
- DEFENSE INDUSTRY
- PETROL AND OIL
- CERAMIC INDUSTRY
- MEDICAL INDUSTRY



ADVANTAGES

- 1) Solid particles may pass through the pump.
- 2) Maintenance cost is low.
- 3) Liquid flow rate can also be adjusted when the air inlet pressure of the pump is adjusted.
- 4) The pump's air valve and pilot valve repair kits can be repaired without disassembling the pump.
- 5) It has the feature of working dry.
- 6) The suction depth of this pump is 6 m.
- 7) The liquid connection of the pump can be both flange and threaded.
- 8) It can be preferred where the pump outlet pressure should be higher than 7 bar.

PUMP TECHNICAL SPECIFICATIONS

- Max. Capacity** : 75 l/min
- Fluid Inlet-Outlet** : 1"
- Max. Fluid Discharge** : 14 bar
- Body Material** : Aluminum, Cast Iron, Stainless Steel
- Air Inlet Size** : 1/2"
- Solid Particle Size** : 4 mm
- Dry Suction Depth** : 6 m
- Max Air Pressure** : 7 bar
- Diaphragm Options** : Santoprene, Neoprene, Buna-N, EPDM, Viton
- Ball Options** : Santoprene, Neoprene, Buna-N, EPDM, Viton
- Ball Seat Options** : Santoprene, Neoprene, Buna-N, EPDM, Viton

DIAPHRAGM PUMPS PERFORMANCE CURVES

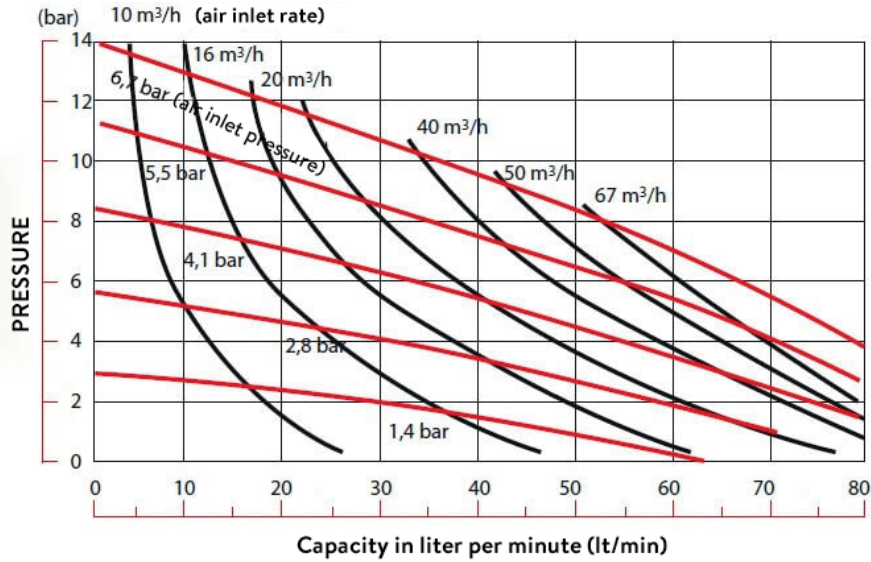

PUMP EXTERNAL DIMENSIONS

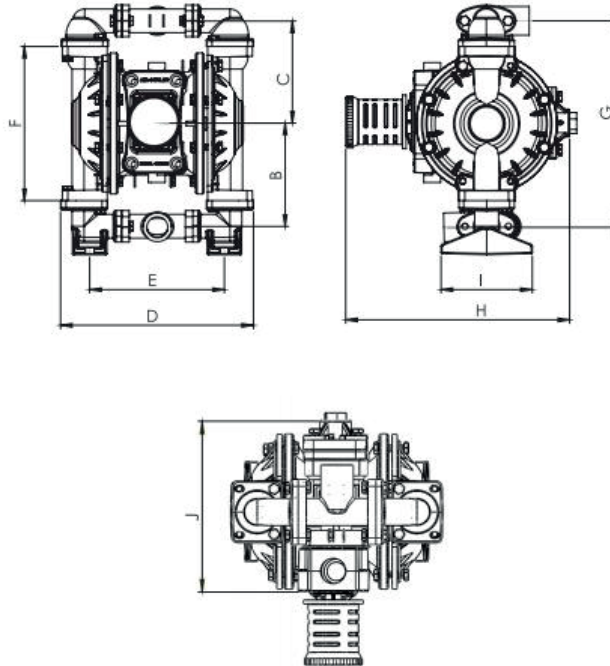

A	B	C	D	E	F	G	H	I	J
356	146	146	274	191	220	293	312	130	220



APPLICATION AREAS:



- | | |
|-----------------------|--------------------|
| WASTE WATER TREATMENT | MARINE |
| TEXTILE | MACHINE-AUTOMATION |
| PACKAGING | DEFENSE INDUSTRY |
| AUTOMOTIVE | PETROL AND OIL |
| FOOD INDUSTRY | CERAMIC INDUSTRY |
| PAINT INDUSTRY | MEDICAL INDUSTRY |
| MINING - ENERGY | |

ADVANTAGES



- 1) Solid particles may pass through the pump.
- 2) Maintenance cost is low.
- 3) Liquid flow rate can also be adjusted when the air inlet pressure of the pump is adjusted.
- 4) The pump's air valve and pilot valve repair kits can be repaired without disassembling the pump.
- 5) It has the feature of working dry.
- 6) The suction depth of this pump is 6 m.
- 7) The liquid connection of the pump can be both flange and threaded.
- 8) It can be preferred where the pump outlet pressure should be higher than 7 bar.

PUMP TECHNICAL SPECIFICATIONS



- | | |
|-----------------------------|---|
| Max. Capacity | : 200 l/min |
| Fluid Inlet-Outlet | : 1½" |
| Max. Fluid Discharge | : 14 bar |
| Body Material | : Aluminum, Cast Iron, Stainless Steel |
| Air Inlet Size | : 3/4" |
| Solid Particle Size | : 6 mm |
| Dry Suction Depth | : 6 m |
| Max Air Pressure | : 7 bar |
| Diaphragm Options | : Santoprene, Neoprene, Buna-N, EPDM, Viton |
| Ball Options | : Santoprene, Neoprene, Buna-N, EPDM, Viton |
| Ball Seat Options | : Santoprene, Neoprene, Buna-N, EPDM, Viton |

DIAPHRAGM PUMPS PERFORMANCE CURVES

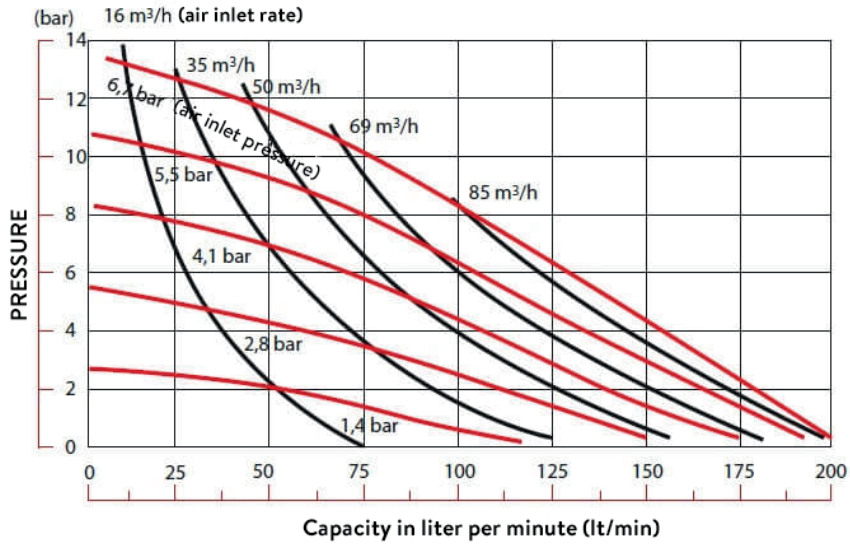

PUMP EXTERNAL DIMENSIONS

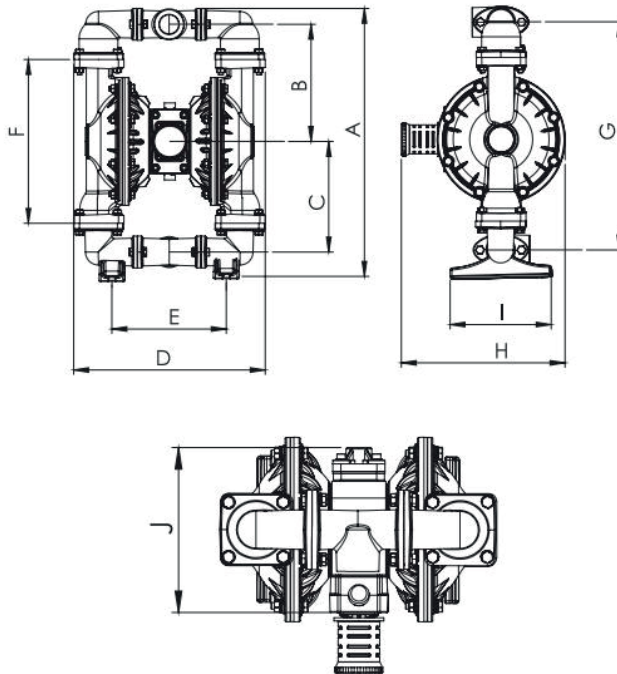

A	B	C	D	E	F	G	H	I	J
605	260	245	425	253	363	505	363	224	253



APPLICATION AREAS:



- | | |
|-----------------------|--------------------|
| WASTE WATER TREATMENT | MARINE |
| TEXTILE | MACHINE-AUTOMATION |
| PACKAGING | DEFENSE INDUSTRY |
| AUTOMOTIVE | PETROL AND OIL |
| FOOD INDUSTRY | CERAMIC INDUSTRY |
| PAINT INDUSTRY | MEDICAL INDUSTRY |
| MINING - ENERGY | |

ADVANTAGES



- 1) Solid particles may pass through the pump.
- 2) Maintenance cost is low.
- 3) Liquid flow rate can also be adjusted when the air inlet pressure of the pump is adjusted.
- 4) The pump's air valve and pilot valve repair kits can be repaired without disassembling the pump.
- 5) It has the feature of working dry.
- 6) The suction depth of this pump is 6 m.
- 7) The liquid connection of the pump can be both flange and threaded.
- 8) It can be preferred where the pump outlet pressure should be higher than 7 bar.

PUMP TECHNICAL SPECIFICATIONS



- | | |
|-----------------------------|---|
| Max. Capacity | : 280 l/min |
| Fluid Inlet-Outlet | : 2" |
| Max. Fluid Discharge | : 14 bar |
| Body Material | : Aluminum, Cast Iron, Stainless Steel |
| Air Inlet Size | : 3/4" |
| Solid Particle Size | : 6 mm |
| Dry Suction Depth | : 6 m |
| Max Air Pressure | : 7 bar |
| Diaphragm Options | : Santoprene, Neoprene, Buna-N, EPDM, Viton |
| Ball Options | : Santoprene, Neoprene, Buna-N, EPDM, Viton |
| Ball Seat Options | : Santoprene, Neoprene, Buna-N, EPDM, Viton |

DIAPHRAGM PUMPS PERFORMANCE CURVES

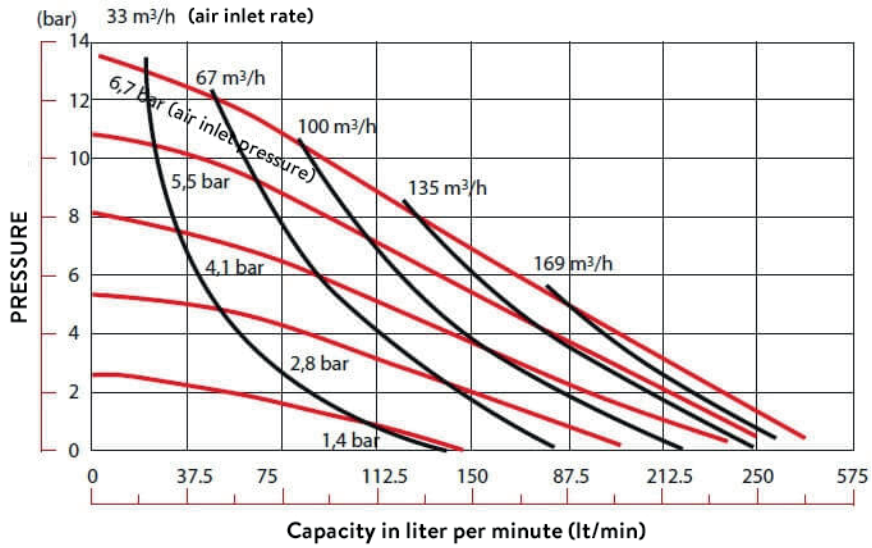

PUMP EXTERNAL DIMENSIONS

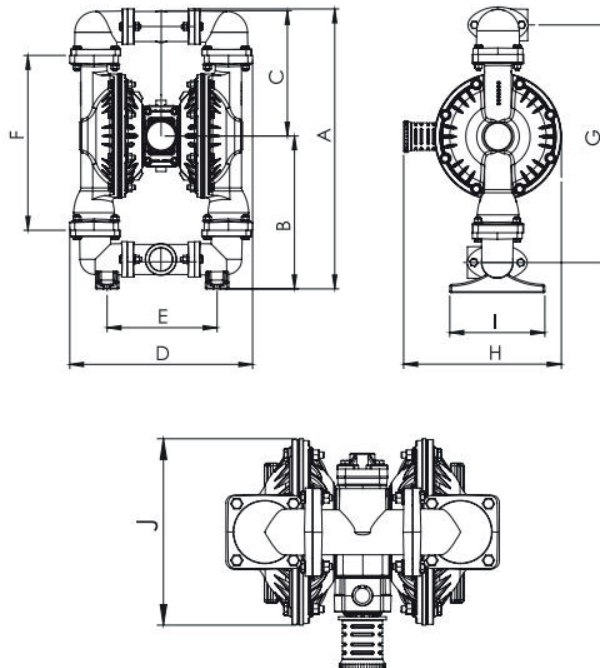

A	B	C	D	E	F	G	H	I	J
669	365	299	438	263	418	556	370	223	298



APPLICATION AREAS:



- WASTE WATER TREATMENT
- MARINE
- TEXTILE
- MACHINE-AUTOMATION
- PACKAGING
- DEFENSE INDUSTRY
- AUTOMOTIVE
- PETROL AND OIL
- FOOD INDUSTRY
- CERAMIC INDUSTRY
- PAINT INDUSTRY
- MEDICAL INDUSTRY
- MINING - ENERGY

ADVANTAGES



- 1) Solid particles may pass through the pump.
- 2) Maintenance cost is low.
- 3) Liquid flow rate can also be adjusted when the air inlet pressure of the pump is adjusted.
- 4) The pump's air valve and pilot valve repair kits can be repaired without disassembling the pump.
- 5) It has the feature of working dry.
- 6) The suction depth of this pump is 6 m.
- 7) The liquid connection of the pump can be both flange and threaded.
- 8) It can be preferred where the pump outlet pressure should be higher than 7 bar.

PUMP TECHNICAL SPECIFICATIONS



- Max. Capacity** : 445 l/min
- Fluid Inlet-Outlet** : 3"
- Max. Fluid Discharge** : 14 bar
- Body Material** : Aluminum, Cast Iron, Stainless Steel
- Air Inlet Size** : 3/4"
- Solid Particle Size** : 8 mm
- Dry Suction Depth** : 6 m
- Max Air Pressure** : 7 bar
- Diaphragm Options** : Santoprene, Neoprene, Buna-N, EPDM, Viton
- Ball Options** : Santoprene, Neoprene, Buna-N, EPDM, Viton
- Ball Seat Options** : Santoprene, Neoprene, Buna-N, EPDM, Viton

DIAPHRAGM PUMPS PERFORMANCE CURVES

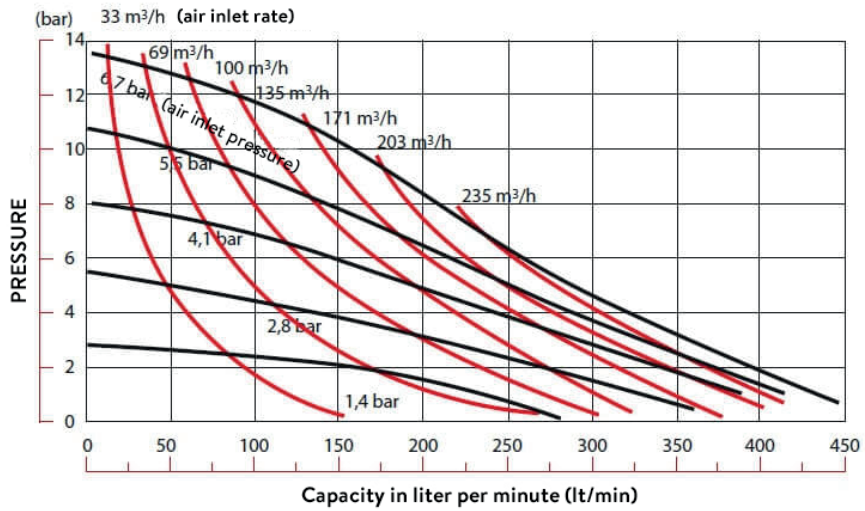

PUMP EXTERNAL DIMENSIONS

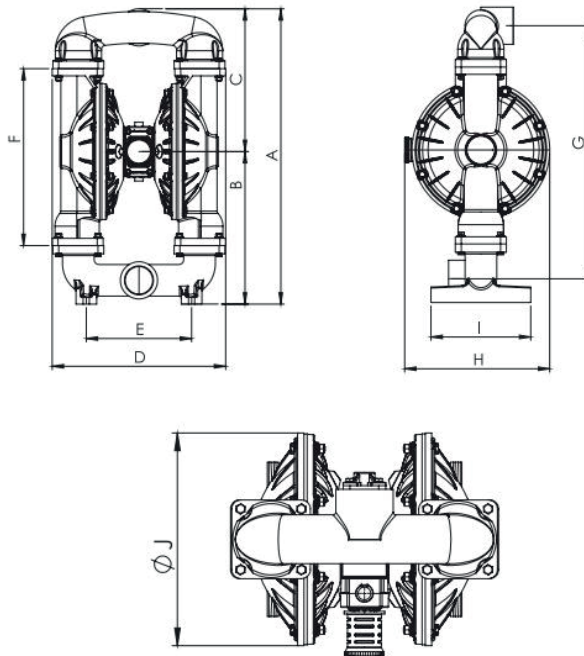

A	B	C	D	E	F	G	H	I	J
858	443	415	504	306	514	735	421	290	400



APPLICATION AREAS

-
- WASTE WATER TREATMENT
 MINING - ENERGY
- TEXTILE
 MARINE
- PACKAGING
 MACHINE-AUTOMATION
- AUTOMOTIVE
- FOOD INDUSTRY
- PAINT INDUSTRY

ADVANTAGES

-
- 1) Solid particles may pass through the pump.
- 2) Maintenance cost is low.
- 3) Liquid flow rate can also be adjusted when the air inlet pressure of the pump is adjusted.
- 4) The pump's air valve and pilot valve repair kits can be repaired without disassembling the pump.
- 5) It has the feature of working dry.
- 6) The suction depth of this pump is 6 m.
- 7) It can provide the transfer of two different liquids at the same time without mixing with each other.

PUMP TECHNICAL SPECIFICATIONS

-
- Max. Capacity** : 55 l/min
- Fluid Inlet-Outlet** : 3/4"
- Max. Fluid Discharge** : 7 bar
- Body Material** : Aluminum, Cast Iron, Stainless Steel
- Air Inlet Size** : 1/4"
- Solid Particle Size** : 3 mm
- Dry Suction Depth** : 6 m
- Max Air Pressure** : 7 bar
- Diaphragm Options** : Santoprene, Neoprene, Buna-N, EPDM, Teflon, Viton
- Ball Options** : Santoprene, Neoprene, Buna-N, EPDM, Teflon, Viton
- Ball Seat Options** : Santoprene, Neoprene, Buna-N, EPDM, Teflon, Viton

DIAPHRAGM PUMPS PERFORMANCE CURVES

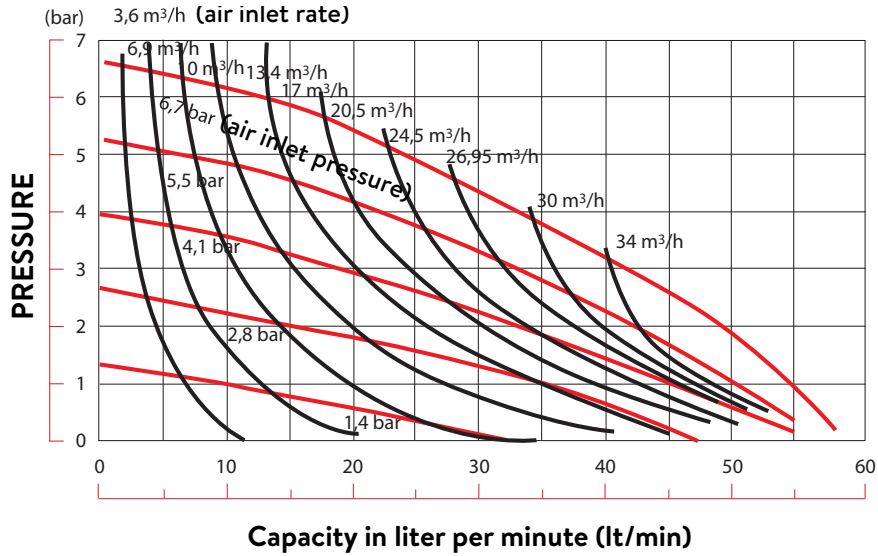

PUMP EXTERNAL DIMENSIONS

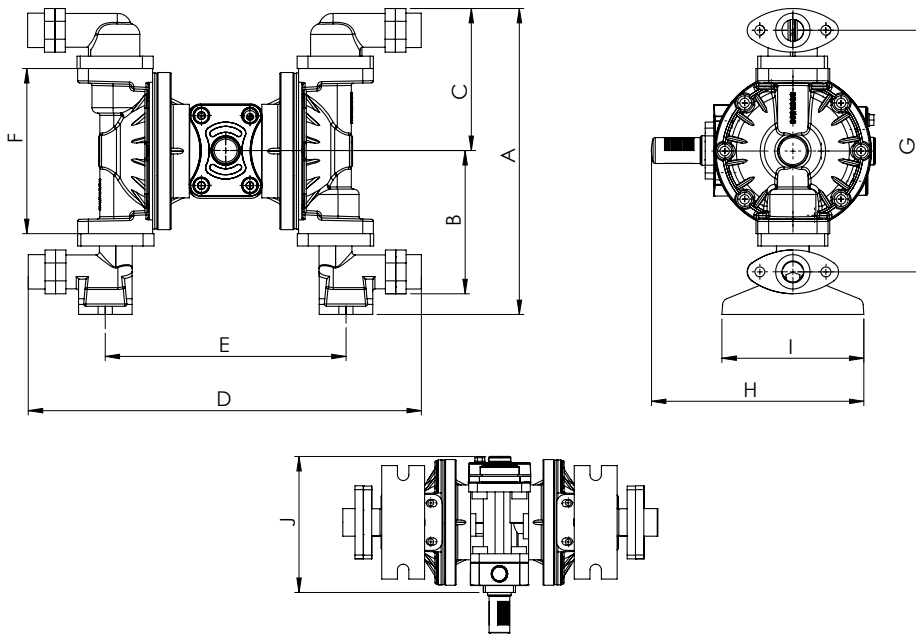

A	B	C	D	E	F	G	H	I	J
280	130	130	360	220	151	221	195	130	163



APPLICATION AREAS

- WASTE WATER TREATMENT
- TEXTILE
- PACKAGING
- AUTOMOTIVE
- FOOD INDUSTRY
- PAINT INDUSTRY
- MINING - ENERGY
- MARINE
- MACHINE-AUTOMATION
- DEFENSE INDUSTRY
- PETROL AND OIL
- CERAMIC INDUSTRY
- MEDICAL INDUSTRY

ADVANTAGES

- 1) Solid particles may pass through the pump.
- 2) Maintenance cost is low.
- 3) Liquid flow rate can also be adjusted when the air inlet pressure of the pump is adjusted.
- 4) The pump's air valve and pilot valve repair kits can be repaired without disassembling the pump.
- 5) It has the feature of working dry.
- 6) The suction depth of this pump is 6 m.
- 7) It can provide the transfer of two different liquids at the same time without mixing with each other.

PUMP TECHNICAL SPECIFICATIONS

- Max. Capacity** : 150 l/min
- Fluid Inlet-Outlet** : 1"
- Max. Fluid Discharge** : 7 bar
- Body Material** : Aluminum, Cast Iron, Stainless Steel
- Air Inlet Size** : 1/2"
- Solid Particle Size** : 4 mm
- Dry Suction Depth** : 6 m
- Max Air Pressure** : 7 bar
- Diaphragm Options** : Santoprene, Neoprene, Buna-N, EPDM, Teflon, Viton
- Ball Options** : Santoprene, Neoprene, Buna-N, EPDM, Teflon, Viton
- Ball Seat Options** : Santoprene, Neoprene, Buna-N, EPDM, Teflon, Viton

DIAPHRAGM PUMPS PERFORMANCE CURVES

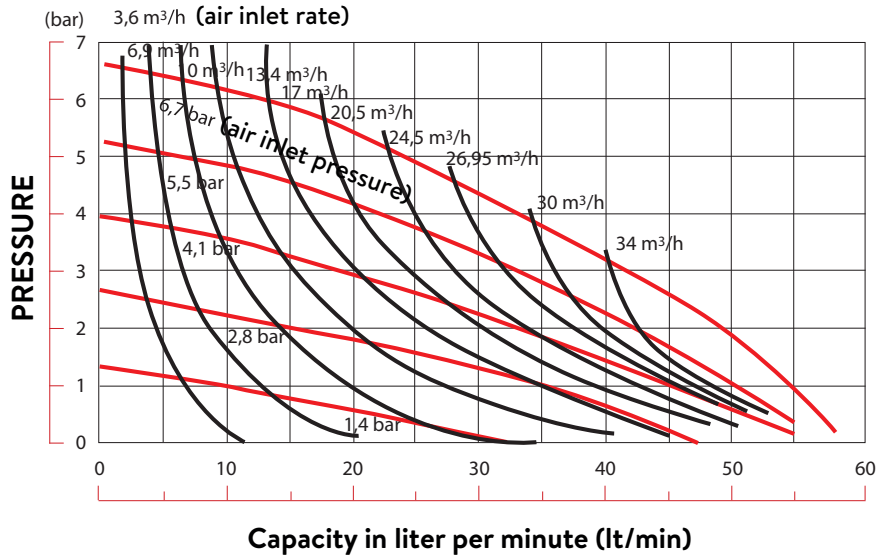

PUMP EXTERNAL DIMENSIONS

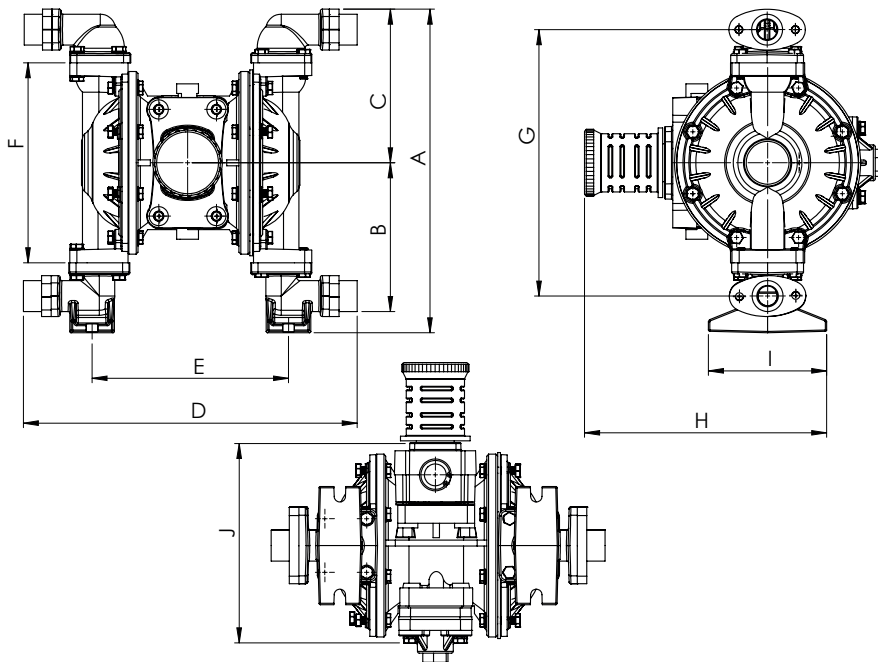

A	B	C	D	E	F	G	H	I	J
356	164	169	367	216	220	293	267	130	220